



Standard Electric Works Co., Ltd. (SEW), established in 1973, manufactures and sells test and measurement instruments worldwide. Our product line includes earth resistance testers, high voltage (H.V.) insulation testers, ELCB testers, loop Impedance/PSCC testers, clamp meters, phase sequence indicators, cable tracers, H.V. detectors, H.V. probe meters, sound level meters, light meters, multitesters, panel meters and test leads. We pride ourselves in offering our customers quality products and superior service.

SEW has a proven track record of developing products which have passed industry standard certifications such as the ISO 9001:2000 Quality Assurance certification and CE/UL Certification. **SEW** continues to invest in research and development to introduce new product lines and features to meet current market demand. **SEW** can also develop customized products to meet your specific applications.

Our reputation and credibility has earned us the respect of our peers in the test and measurement industry. We look forward to the opportunity to discuss how we can help you to achieve your test and measurement needs.



Since 1998, **TOPTRONIC** has selected **SEW** as their manufacturing partner and entered into a joint venture agreement because of SEW's outstanding long record of manufacturing Test and Measuring Equipments.

Toptronic act as the Test and Measurement Technology provider to SEW and develop the Intellectual Property of the products. Wherever you see the Toptronic logo in the catalogue, it explains what contribution is provided by Toptronic to manufacture these world class products.



SEW pride itself of manufacturing only Original Designs which are the results of years of research, prototypes and which have been field tested by specialists users.

Together with Toptronic, we manufacture products which are unique and fill the gap in a specialized market. When buying a SEW product, in addition to investing in an instrument of the highest quality, you are availing yourself on the Toptronic international expertise.

1100 SERIES

- DIGITAL MULTIFUNCTION AND INSULATION CONTINUITY-VOLTAGE TESTER



1151 IN \ 1152 MF 1

1500 & 2500 SERIES

- DIGITAL INSULATION TESTER
- ANALOG INSULATION TESTER
- DIGITAL EARTH RESISTANCE TESTER
- ANALOG EARTH RESISTANCE TESTER
- ANALOG AUDIO IMPEDANCE TESTER



ST-2550 \ ST-2551 3
 ST-1503 \ ST-1504 4
 ST-1520 5
 ST-1505 6
 1506 IM 6

1800 SERIES

- DIGITAL INSULATION TESTER
- ANALOG INSULATION TESTER
- DIGITAL EARTH RESISTANCE TESTER
- ANALOG EARTH RESISTANCE TESTER
- DIGITAL ELCB TESTER
- ANALOG ELCB TESTER
- DIGITAL LOOP IMPEDANCE/PSC/LORD TESTER
- DIGITAL LOOP IMPEDANCE/PSC/LORD TESTER
- DIGITAL ELECTRICAL NETWORK ANALYZER



1851 IN 7
 1800 IN \ 1801 IN \ 1832 IN 8
 1820 ER 10
 1805 ER 11
 1811 EL \ 1812 EL \ 1813 EL 12
 810 EL \ 1810 EL 14
 1824 LP 15
 1825 LP 16
 1826 NA 17

2100 SERIES

- DIGITAL EARTH RESISTANCE TESTER
- ANALOG EARTH RESISTANCE TESTER



2120 ER 18
 2105 ER 18

2700 SERIES

- DIGITAL INSULATION TESTER
- ANALOG INSULATION TESTER
- DIGITAL EARTH RESISTANCE TESTER
- ANALOG EARTH RESISTANCE TESTER
- DIGITAL AUDIO IMPEDANCE TESTER
- DIGITAL ELCB TESTER
- HIGH VOLTAGE PROVING UNIT
- DIGITAL ELECTRICAL NETWORK ANALYZER



2751 IN 19
 2732 IN 20
 2720 ER \ 2734 ER 21
 2705 ER 23
 2706 IM 23
 2712 EL 24
 2713 PU 25
 2726 NA 26

2800 SERIES

- DIGITAL INSULATION TESTER
- DIGITAL H.V. INSULATION TESTER
- DIGITAL LOOP IMPEDANCE/PSC TESTER
- DIGITAL ELCB TESTER



2801 IN 27
 2803 IN \ 2804 IN 28
 2811 LP 29
 2820 EL 30

4100 SERIES

- MULTIFUNCTION AND INSULATION CONTINUITY-VOLTAGE TESTER
- ANALOG INSULATION TESTER
- DIGITAL H.V. INSULATION TESTER
- DIGITAL EARTH RESISTANCE TESTER
- ANALOG EARTH RESISTANCE TESTER
- DIGITAL ELCB TESTER
- DIGITAL ELECTRICAL NETWORK ANALYZER
- DIGITAL MILLIOHM METER
- PHASE AND MOTOR ROTATION TESTER
- CABLE PHASING METER



4101 IN \ 4102 MF 31
 4132 IN 33
 4103 IN \ 4104 IN 34
 4120 ER \ 4134 ER 35
 4105 ER 35
 4112 EL 37
 4126 NA 38
 4136 mO \ 4137 mO 39
 4156 PR 40
 4183 CP 41

INDEX

- ANALOG MULTIFUNCTION INSULATION/ VOLTAGES/EARTH RESISTANCE TESTER
- DIGITAL MULTIFUNCTIONS AND INSULATION CONTINUITY-VOLTAGE TESTERS

6200 SERIES

- ANALOG H.V. INSULATION TESTER
- DIGITAL H.V. INSULATION TESTER
- DIGITAL ELCB TESTER
- DIGITAL EARTH RESISTANCE TESTER(4 WIRES)
- DIGITAL LOW RESISTANCE OHM METER



HIGH VOLTAGE SERIES

- H.V. PROXIMITY DETECTOR
- H.V. DETECTOR
- H.V. PROBE METER
- PERSONAL SAFETY VOLTAGE DETECTOR
- H.V. PROBE
- H.V. MULTIFUNCTION PHASING STICKS
- CAPACITIVE H.V. DETECTORS(CONTACT)

HOT STICK

OVERHEAD LINES CONTACT VOLTAGE DETECTOR & LOW VOLTAGE INDICATOR

SOUND LEVEL METER

LIGHTMETER

CABLE TRACER

CIRCUIT BREAKER IDENTIFIER

PHASE SEQUENCE INDICATOR

AC LINE SEPARATOR

ROTARY SCALE CLAMP METER

DIGITAL CLAMP METER

DIGITAL AC LEAKAGE CLAMPMETER

DIGITAL+ANALOG MULTITESTER

DIGITAL MULTITESTER

ANALOG MULTITESTER

RESISTOR CALIBRATION BOX

MINI APPLIANCE CHECKER

TEST LEADS & TERMINALS

4167 MF	42
4152 IN、4153 IN、4154 MF、4155MF、4156 IN、4157 MF、4158 MF、4159 MF、4160MF	43
6200 IN、6201 IN	47
6210AIN、6211AIN、6212AIN	48
6220 EL、6221 EL	50
6230 ER	51
6237 DLRO	52
270 HP、275 HP	53
276 HD、276S HD、285 HD	55
PD-40AM	56
288 SVD	57
PD-20、PD-20S、PD-28	58
PCxxK	59
21x HVD	61
HS-120	62
LVD-415	63
2310 SL	64
2330 LX	64
180 CB	65
190 CBI、191CBI、188 FFF	65
ST-850、855 PR、862 PR、863 PR	67
888 PMR、887 PR(LCD)	69
ST-860	71
ALS-1	71
ST-375、ST-600、ST-1000、1010 CL	72
ST-2600、3800 CL、3810 CL	73
ST-3600、ST-3602、ST-3620	74
3900 CL、3902 CL、3904 CL	75
3920 CL、3921 CL.....	76
ST-3502.....	77
ST-3201、ST-3501.....	78
ST-365TR、ST-360TR _N 、ST-505、ST-520..	79
RCB-1、RCB-3、ITC-6、ITC 8	80
880 AT	81
.....	82

DIGITAL INSULATION TESTER (1kV below) SELECTION GUIDE

Model	1151 IN	ST-2550	ST-2551	1851 IN	2751 IN	2801 IN	4101 IN
Insulation Test Voltage	250V /2GΩ	250V /2000MΩ	250V /2000MΩ	250V /200MΩ	250V /2000MΩ	250V /1000MΩ	250V /2000MΩ
	500V /4GΩ	500V /2000MΩ	500V /2000MΩ	500V /200MΩ	500V /2000MΩ	500V /2000MΩ	500V /4000MΩ
	1000V /8GΩ	1000V /2000MΩ	1000V /2000MΩ	1000V /2000MΩ	1000V /2000MΩ	1000V /3000MΩ	1000V /8000MΩ
Continuity Test Ranges	0-2000Ω	200Ω	20Ω/200Ω/2000Ω	20Ω/2000Ω	20Ω/200Ω/2000Ω	0/0.5/5/50/500Ω	0-2000Ω
Voltage Range(ACV)	700V	600V	600V	600V	600V		700V
Voltage Range(DCV)	950V						950V
Display	LCM	3½digit	3½digit	3½digit	3½digit	LCM	LCM
Microprocessor Controlled	●					●	●
Bargraph	●					●	●
Data Hold	●				●	●	●
Counting Timer	●					●	●
Long Test	●	●	●	●	●	●	●
Auto Range	●	●	●		●	●	●
Auto Null	●					●	●
Auto Power Off	●	●	●		●	●	●
Auto Discharge	●				●	●	●
External Voltage Warning Indication	●					●	●
Fuse Protection	●			●	●	●	●
Live Circuit Warning	●			●	●	●	●
Water Proof (once the lid secured)	●						●
CE Approved	●	●	●	●	●	●	●
B.S. 16th Edition	●			●	●	●	●
Page	1	3	3	7	19	27	31

ANALOG INSULATION TESTER (1kV below) SELECTION GUIDE

Model	ST-1503	ST-1504	1800 IN	1801 IN	1832 IN	2732 IN	4132 IN
Insulation Resistance Ranges		250V /100MΩ	250V /100MΩ	50V /20MΩ	250V /100MΩ	250V /100MΩ	250V /100MΩ
	500V /1000MΩ	500V /200MΩ	500V /200MΩ	125V /50MΩ	500V /200MΩ	500V /200MΩ	500V /200MΩ
	1000V /2000MΩ	1000V /400MΩ	1000V /400MΩ	250V /100MΩ	1000V /400MΩ	1000V /400MΩ	1000V /400MΩ
Continuity Test Ranges	100Ω	100Ω	50Ω	50Ω	3Ω /500Ω	3Ω /500Ω	3Ω /500Ω
Voltage Range(ACV)	600V	600V	600V	600V	600V	600V	600V
Taut Band Movement	●	●	●	●	●	●	●
Mirror Scale					●	●	●
Battery Check	●	●	●	●	●	●	●
Auto Discharge	●	●	●	●	●	●	●
External Voltage Warning Indication					●	●	●
Live Circuit Warning					●	●	●
Fuse Protection	●	●	●	●	●	●	●
Long / Hand Free Testing Locker			●	●	●	●	●
CE Approved	●	●	●	●	●	●	●
B.S. 16th Edition					●	●	●
Page	4	4	8	8	9	20	33

DIGITAL H.V. INSULATION TESTER (1kV up) SELECTION GUIDE

Model	2803 IN	2804 IN	4103 IN	4104 IN	6210A IN	6211A IN	6212A IN
Insulation Test Voltage	0.5kV /20GΩ	1kV /50GΩ	0.5kV /30GΩ	1kV /60GΩ	0.5kV /20GΩ	1kV /50GΩ	25GΩ(0.5kV)~ 500GΩ(10kV)
	1kV /50GΩ	2.5kV /125GΩ	1kV /60GΩ	2.5kV /150GΩ	1kV /50GΩ	2.5kV /125GΩ	
	2.5kV /125GΩ	5kV /250GΩ	2.5kV /150GΩ	5kV /300GΩ	2.5kV /125GΩ	5kV /250GΩ	
	5kV /250GΩ	10kV /500GΩ	5kV /300GΩ	10kV /600GΩ	5kV /250GΩ	10kV /500GΩ	
Display	LCM	LCM	LCM	LCM	LCM	LCM	LCM
Microprocessor Controlled	●	●	●	●	●	●	●
Bargraph	●	●	●	●	●	●	●
Counting Timer	●	●	●	●	●	●	●
Long Test	●	●	●	●	●	●	●
Auto Range	●	●	●	●	●	●	●
Auto Power Off	●	●	●	●	●	●	●
Auto Discharge	●	●	●	●	●	●	●
External Voltage Warning Indication	●	●	●	●	●	●	●
Live Circuit Warning	●	●	●	●	●	●	●
Low Battery Indicator	●	●	●	●	●	●	●
EEPROM Calibration	●	●	●	●	●	●	●
Water Proof			●	●			
CE Approved	●	●	●	●	●	●	●
Page	28	28	34	34	48	48	49

DIGITAL EARTH RESISTANCE TESTER SELECTION GUIDE

Model	ST-1520	1820 ER	2120ER	2720 ER	2734 ER	4120 ER	4134 ER	6230 ER
Earth Resistance Test	20 /200 /2000Ω	20 /200 /2000Ω	20 /200 /2000Ω	20 /200 /2000Ω	20 /200 /2000Ω	20 /200 /2000Ω	20 /200 /2000Ω	2 /20 /200 /2000 /20kΩ
Earth Voltage Test(ACV)	200V	200V	200V	200V	200V	200V	200V	200V
Soil Resistivity Test					●		●	●
Terminal	3	3	3	3	4	3	4	4
Display	2000	2000	2000	2000	2000	2000	2000	2000
Microprocessor Controlled					●		●	●
Data Hold	●	●	●	●	●	●	●	●
Auto Power Off	●				●		●	●
Test Counting Timer					●		●	●
High Noise Rejection					●		●	●
Low Battery Indication	●	●	●	●	●	●	●	●
Over Range Indication	●	●	●	●	●	●	●	●
Open Circuit Indication	●	●	●	●	●	●	●	●
Water Proof			●			●	●	
CE Approved	●	●	●	●	●	●	●	●
Page	5	10	18	21	22	35	36	51

ANALOG EARTH RESISTANCE TESTER SELECTION GUIDE

Model	ST-1505	1805 ER	2105ER	2705 ER	4105 ER
Earth Resistance Test	10 /100 /1000Ω	10 /100 /1000Ω	12 /120 /1200Ω	10 /100 /1000Ω	12 /120 /1200Ω
Earth Voltage Test(ACV)	30V	30V	30V	30V	30V
Terminal	3	3	3	3	3
Auto Power Off	●				
Battery Check	●	●	●	●	●
Open Circuit Indication		●	●	●	●
Long Test	●	●	●	●	●
Lamp For Scale Panel					●
Water Proof			●		●
CE Approved	●	●	●	●	●
Page	6	11	18	23	35

DIGITAL CLAMP METER SELECTION GUIDE

Model	ST-2600	ST-3600	ST-3602	ST-3620	3800 CL	3810 CL	3900 CL	3902 CL	3904 CL
ACA	400A	1500A	1500A	1500A	1000A	1000A	2000A	2000A	2000A
ACV	600V	750V	750V	750V	600V	600V	600V	600V	600V
DCA		1500A	1500A		1000A	1000A	2000A	2000A	2000A
DCV		1000V	1000V		600V	600V	600V	600V	600V
Resistance	4KΩ	1500Ω	1500Ω	200Ω	2KΩ	2KΩ	40MΩ	20MΩ	40MΩ
Continuity	●		●	●	●	●	●	●	●
Frequency							40MHz	20MHz	40MHz
Capacitance								2mF	4mF
Diode		●	●		●	●		●	●
Display (LCD counts)	4000	2000	2000	2000	4000	4000	4000	2000	4000
Bargraph							●		
Auto Range	●		●		●	●	●	●	●
Auto Power Off							●	●	●
Auto Null							●		
Data Hold	●	●	●	●	●	●	●	●	●
Max./Min. Mode					Max.	Max.	Max. / Min.		
Peak Hold				●			●		
Buzzer	●		●	●	●	●	●	●	●
Low Battery Indication	●	●	●	●	●	●	●	●	●
Over Range Indication	●	●	●	●	●	●			
Conductor Size	27mm	55mm	55mm	55mm	40mm	40mm	55mm	55mm	55mm
True RMS						●			
CE Approved	●				●	●	●	●	●
Page	73	74	74	74	73	73	75	75	75

1151 IN

1152 MF

- This Family (1151 IN and 1152 MF) of Originally Designed Unique Products have features ranging from Insulation Resistance Testing, Voltage (ac-dc) measurements with Automatic Hold facility, Continuity Test with a short circuit current of minimum 200mA.
- **Two very unique features are found on the Multifunction Model 1152MF; MOV and Gas Arrester Testing.**
- Today, most equipments and electrical installations are protected by MOVs and Gas arresters.
- The 1152MF can test these devices to establish if the devices are still operating correctly or not.
- Energy conservation is featured on all these new Advanced Products.
- EnerSave™ limits the test duration to about 10 Seconds to save energy.
- This new generation of test equipments have no moving parts. All calibration are saved internally in a non volatile memory.
- Calibration can be done at any calibration facility around the world, without the need for dedicated calibration equipment.
- This makes these products easier to maintain and lower the cost of calibration and ownership.
- Their calibration interval can be extended without much problem.
- They comply to all the latest regulations, including UK 16 Edition.
- This product family is part of our new World Class series.™
- They prominently feature heavy duty protections in their circuitry.
- Meets IEC/EN 61010-1 CAT III 600V

FEATURES COMPARISON

	1151IN	1152MF
Digital EE Calibration (No Potentiometers)	■	■
Keypad Operation	■	■
Automatic Voltmeter AC/DC at Start / Reset	■	■
ON-Reset/Restart Key	■	■
Off Push Button (press more than 5 Sec on 1kV key)	■	■
Auto-Off	■	■
MOV / Protection Devices Test	■	■
Test ON-OFF	■	■
Polarization Index (PI) on 250, 500 and 1000V	■	■
Dielectric Absorption Ratio (DAR) on 250, 500 and 1000V	■	■
Battery Test	Test Battery at Start	Test Battery at Start
Battery Test at Switch ON / Reset	■	■
Voltmeter on request by Keypad	Automatic	Automatic
Safety Voltmeter before each Test	■	■
Auto-Discharge on all Test and all Ranges	■	■
Continuity Short Circuit Current >220mA (225mA Typical)	■	■
Continuity Open Circuit Voltage of 5V dc	■	■
Nominal Voltage @ 1mA on all Insulation Ranges	■	■
Buzzer ON/OFF by Key	Always ON	Always ON
Leads Auto-Null key	■	■
Test Auto-Stop	■	■
Display Customization for OEM	■	■
Re-programmable Microprocessor for Easy Updates	■	■
Can be calibrated in ALL calibration laboratories	■	■
Insulation measurement from 2kΩ (250V range) to 8GΩ (1kV Range)	■	■
Continuity from 0.01Ω (220mA) to 1999Ω	■	■
DC Voltmeter from ±1Vdc to ±950Vdc	■	■
AC Voltmeter from 1Vac to 700Vac	■	■
Accept 8 Rechargeable Batteries or Alkaline or Normal	■	■
Smart Hold & Stop on Voltmeter ac / dc	■	■
Gas Arrester Function	■	■
EnerSave™	■	■



STANDARD DIGITAL MULTIFUNCTION AND INSULATION CONTINUITY-VOLTAGE TESTER

SPECIFICATIONS

Insulation Test	1151 IN	1152 MF
Test Voltage (DC V)	250V/500V/1000V	250V/500V/1000V
Output Voltage @ 1mA	Retest Voltage +10% Max	
Measuring Ranges	2K-2G/4K-4G/8K-8G Ω	2K-2G/4K-4G/8K-8G Ω
Accuracy	<30kΩ:±20%rdg 30kΩ-1MΩ:±5%rdg >1MΩ:±3%rdg	<30kΩ:±20%rdg 30kΩ-1MΩ:±5%rdg >1MΩ:±3%rdg
When Voltage is constant, Current is Limited at	±1.2mA	±1.2mA
Short Circuit Current	±4mA Max	±4mA Max

Continuity Test

Measuring Ranges	0.01-1999Ω	0.01-1999Ω
Accuracy	0.01-100Ω : ±1.0% rdg 100-300Ω : ±1.5% rdg 300-1999Ω : ±2.0% rdg	0.01-100Ω : ±1.0% rdg 100-300Ω : ±1.5% rdg 300-1999Ω : ±2.0% rdg
Short Circuit Current	> 220mA	>220mA
Open Circuit Voltage	5V dc	5Vdc
Resolution	±2 counts	±2counts

Voltmeter

AC Voltage(Auto)	0-700V	0-700V
DC Voltage(Auto)	0-950V	0-950V
Accuracy	±1.5% of F.S.	±1.5% of F.S.
Resolution	±1V	±1V

MOV Test

Test Voltage	—————	5-1020Vdc
Voltage Result Accuracy	—————	±3%
Voltage Result Resolution	—————	±2 counts

GAS Arrester Test

Test Voltage	—————	5-1020Vdc
Voltage Result Accuracy	—————	±3%
Voltage Result Resolution	—————	±2 counts

Protections

Over Load	700V (between all terminals)
Over Voltage	Class III-700V towards ground
Fuses	1 X 500mA, 5 x 20mm, HBC, 600 Fast Blow

General

Display	2 lines x 16 characters LCD
Auto-Null Threshold	5Ω
Buzzer Threshold	3Ω
Fast Test	10Sec
Long Test	60Sec
With PI and DAR test Function	10Min
Load Battery Test Current	About 300mA
Power Source	1.5 x 8 (Type alkaline)
Dimensions	175(L) x 85(W) x 75(H)mm
Weight	655 g Approx. (battery included)
Operating Temperature	1 °C to 55 °C not in full sun
Storage Temperature	-20 °C to 70 °C
Accessories	Test leads (TEL-AL11-A) Shoulder belt Instruction manual Batteries





CE

ST-2550

CE

ST-2551
FEATURES

- ST-2551 (ST-2550) is a LCD indicated instrument for testing insulation ($M\Omega$), continuity (Ω) and AC voltage.
- Instant operation is possible with a pushbutton. In addition, for continuous measurement of $M\Omega$, Ω or ACV, a convenient timer is provided with automatic power off after three to five minutes to save the battery power.
- LED (red) indication works when testing insulation, continuity and voltage.
- Use a high efficiency and accurate DC-DC converter.
- Auto ranging.
- Heavy case.
- Most suitable for insulation resistance measurement of electrical household appliances, power line distribution and installation.
- IEC 1010 CAT II 600V

SPECIFICATIONS

	ST-2550	ST-2551
Insulation Resistance		
Test Voltage (DC V)	250V/500V/1000V	250V/500V/1000V
Output Voltage Open Circuit	+10%	+10%
Measuring Ranges	0-20M Ω / 0-200M Ω / 0-2000M Ω	0-20M Ω / 0-200M Ω / 0-2000M Ω
Accuracy	20M Ω : \pm (1.5%rdg+2dgt) 200M Ω : \pm (2.5%rdg+2dgt) 2000M Ω : \pm (5%rdg+3dgt)	20M Ω : \pm (1.5%rdg+2dgt) 200M Ω : \pm (2.5%rdg+2dgt) 2000M Ω : \pm (5%rdg+3dgt)
Continuity		
Measuring Ranges	200 Ω	20 Ω / 200 Ω / 2k Ω
Short Circuit Current	3mA	3mA
Accuracy	\pm (1.5%rdg+2dgt)	20 Ω : \pm (2%rdg+4dgt) 200 Ω : \pm (1.5%rdg+2dgt) 2K Ω : \pm (1.5%rdg+2dgt)
Buzzer Sounds Below	10 Ω	8 Ω / 10 Ω / 50 Ω
AC Voltage		
AC Voltage Range	0-600V AC	0-600V AC
Accuracy	\pm (1.5%rdg+2dgt)	\pm (1.5%rdg+2dgt)
General		
Display	LCD 3 $\frac{1}{2}$ (2000counts)	LCD 3 $\frac{1}{2}$ (2000counts)
Impedance	10M Ω	10M Ω
Power Source	1.5V(SUM-3) \times 6	1.5V(SUM-3) \times 6
Dimensions	163(L) \times 100(W) \times 50(D)mm	163(L) \times 100(W) \times 50(D)mm
Weight	Approx. 440g (battery included)	Approx. 480g (battery included)
Accessories	Test leads (AL-24SA) Instruction manual Heavy-duty case Batteries	Test leads (AL-24SA) Instruction manual Heavy-duty case Batteries

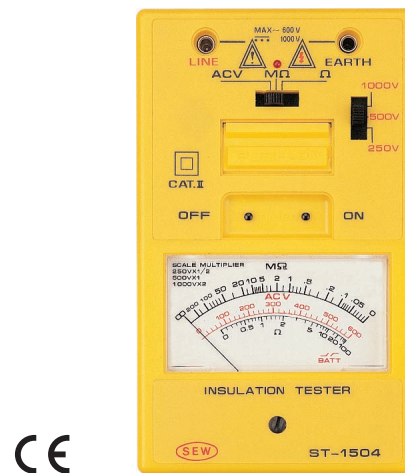

CE

ST-1503

CE

ST-1504
FEATURES

- High quality Taut Band movement.
- It is a light and portable combination instrument for testing insulation ($M\Omega$), continuity (Ω) and AC voltage.
- Instant operation is possible with a pushbutton. In addition, for continuous measurement of $M\Omega$ or Ω , a convenient timer is provided with automatic power off after three to five minutes to save the battery power.
- LED (red) indication works when testing insulation and continuity.
- Use a high efficiency and accurate DC-DC converter.
- Most suitable for insulation resistance measurement of electrical household appliances, power line distribution and installation.
- IEC 1010 CAT II 600V

SPECIFICATIONS
Insulation Resistance

	ST-1503	ST-1504
Test Voltage (DC V)	500V/1000V	250V/500V/1000V
Output Voltage on Open Circuit	+10%	+10%
Measuring Ranges (Mid-scale value)	0-1000M Ω /0-2000M Ω (20M Ω) (40M Ω)	0-100M Ω /0-200M Ω /0-400M Ω (1M Ω) (2M Ω) (4M Ω)
Accuracy	$\pm 5\%$ of scale length	$\pm 5\%$ of scale length
Short Circuit Current	1mA	2mA
Maximum Battery Current	Approx. 80mA(500V) 150mA(1000V)	Approx. 60mA(250V) 80mA(500V) 150mA(1000V)

Continuity

Measuring Range	0-100 Ω	0-100 Ω
Line Frequency Range	40-70Hz	40-70Hz
Open Circuit Voltage	100mV	100mV
Short Circuit Current	50mA	50mA
Accuracy	$\pm 5\%$ of scale length	$\pm 5\%$ of scale length

AC Voltage

AC Voltage Range	0-600V AC	0-600V AC
Accuracy	$\pm 2.5\%$ of full scale	$\pm 2.5\%$ of full scale

General

Power Source	1.5V (SUM-3) $\times 6$	1.5V (SUM-3) $\times 6$
Dimensions	163(L) \times 100(W) \times 50(D)mm	163(L) \times 100(W) \times 50(D)mm
Weight	Approx. 440g (battery included)	Approx. 470g (battery included)
Accessories	Test leads (AL-24SA) Instruction manual Heavy-duty case Batteries	Test leads (AL-24SA) Instruction manual Heavy-duty case Batteries



CE

ST-1520

SPECIFICATIONS

Measurement Ranges	Earth Resistance 0-20Ω/0-200Ω/0-2000Ω Earth Voltage 0-200V AC (40-500Hz)
Accuracy	Earth Resistance ± (2% rdg+2dgt) or ±0.1Ω. which is greater. Earth Voltage ± (1% rdg+2dgt)
Earth Resistance Resolution	0-20Ω (0.01Ω) 0-200Ω (0.1Ω) 0-2000Ω (1Ω)
Measurement System	Earth resistance by constant current inverter 820Hz approx. 2mA.
Low Battery Indication	"B" symbol appears on the display
Data Hold Indication	"DH" symbol appears on the display
Over Range Indication	"1" (MSD)
Open Circuit Indication	LED will be unlit
Display LCD	3½ digit(2000 counts)
Power Source	1.5V(SUM-3)×6. Type AA.
Dimensions	163(L)×100(W)×50(D)mm
Weight	480g approx.(battery included)
Accessories	Test leads (AL-36: red-15m yellow-10m green-5m) Auxiliary earth bars. Heavy-duty case Instruction manual Batteries

FEATURES

- Capable of measuring earth voltage (Vac).
- 2mA measuring current permits the testing of earth resistance without tripping earth leakage current circuit breakers in the circuit.
- Auto power off function. The timer operates automatically about three to five minutes after pressing the "PUSH BUTTON SWITCH" and "TIMER ON BUTTON" are pressed together. This will keep the test "ON" for about three to five minutes. Then auto power off.
- Battery operated.
- Data hold function.
- Small and light weight.
- IEC 1010 CAT III 200V
- *Calibration performed with supplied test leads.*

Earth Voltage Measurement

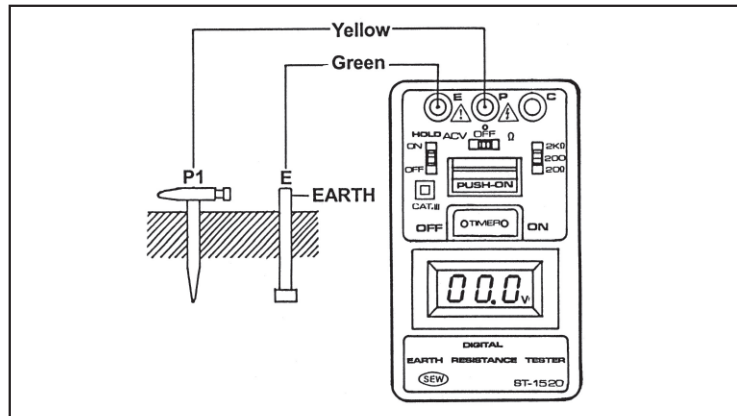

Earth Resistance Measurement

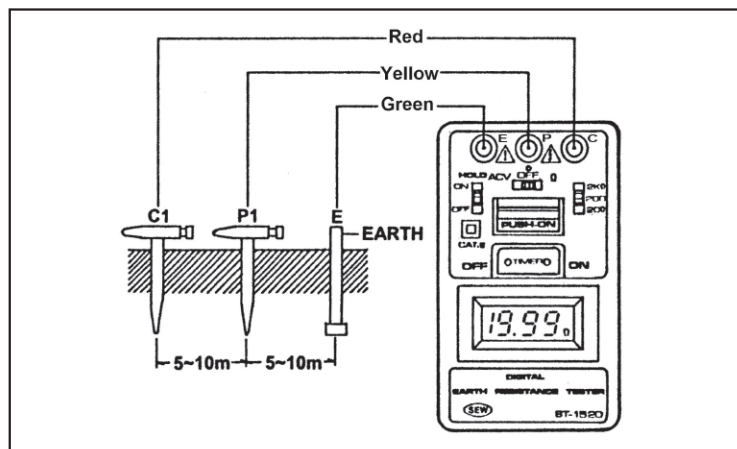



CE

ST-1505

FEATURES

- High quality Taut Band movement.
- Capable of measuring earth voltage (Vac).
- The timer operates automatically for about three to five minutes when the "PUSH BUTTON SWTCH" and "TIMER ON BUTTON" are pressed together. This will keep test "ON" for the duration of the timer.
- Battery life indication.
- Battery replacement can be easily made without removing the carrying case.
- IEC 1010 CAT II 30V
- **Calibration performed with supplied test leads.**

SPECIFICATIONS

Measuring Ranges	Earth Resistance 0-10Ω/0-100Ω/0-1000Ω Earth Voltage 0-30V AC (40-500Hz)
Accuracy	Earth Resistance ± 3% of full scale Earth Voltage ± 2.5% of full scale
Measuring System	Earth resistance by constant current inverter (Square Signal) 820Hz approx. 2mA.
Power Source	1.5V(SUM-3)×6. Type AA.
Dimensions	163(L)×100(W)×50(D)mm
Weight	460g approx.(battery included)
Accessories	Test leads (AL-36: red-15m yellow-10m green-5m) Auxiliary earth bars. Heavy-duty case Instruction manual Batteries



CE

1506 IM

FEATURES

- High quality Taut Band movement.
- Battery-powered audio impedance tester.
- Timer function for hand free use.
- Battery indicator.
- The tester measure with a frequency of 1KHz.
- Measure speaker's impedance.
- Measure speaker lines (connected to load).
- Help to calculate and check audio power systems.
- Ideal for public address installation and maintance.
- Can measure transformer impedances.
- IEC 1010 CAT II 100V

SPECIFICATIONS

Measuring System	Constant current inverter with 1KHz approx. 2mA
Measuring Ranges	20Ω/200Ω/2KΩ
Accuracy	±2.5% of full scale
Power Source	1.5V (SUM-3) x 6
Dimensions	163(L) x 100(W) x 50(D)mm
Weight	Approx.420g (battery included)
Accessories	Test leads (AL-24SA) Heavy-duty case Instruction manual Batteries

Test leads

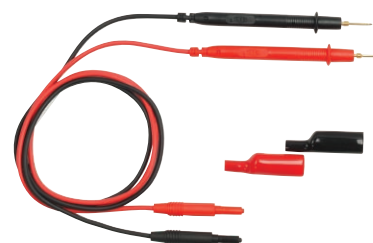



1851 IN

WHY TEST IS NECESSARY?

Insulation

Every electrical apparatus and installation need to be safe for the user and for the equipment itself.

Electrical conductors of electricity need to be insulated from each other, so that they do not create electrical hazard or unnecessary consumption.

Bad insulated circuits can create leakage current which can be dangerous and trip your GFCI, RCCB or ELCB.

Each country regulates those levels at which the insulation is acceptable.

Generally, Insulation resistance measurement should be done between each conductor and the earth, and between each conductors.

Continuity

Checking the continuity of wires, complete circuits, connections, closure of contacts, circuit breakers, fuses, bounding resistance of connections, etc... are all very important.

Test Leads Connections

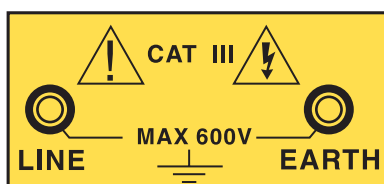

FEATURES

- A LCD indicated instrument for insulation ($M\Omega$), continuity(Ω) and AC Voltage.
- Three insulation test voltage (DC): 250V, 500V, 1000V.
- 3-1/2 digital LCD (2000 counts).
- 68 x 34mm large LCD display.
- Test insulation at rated voltage into a 1mA load.
- 200mA short circuit continuity current.
- External voltage warning indication.
- Automatic circuit discharge.
- Fuse protection.
- IEC/EN 61010-1 CAT III 600V
- BS 16th edition.

SPECIFICATIONS

Insulation Resistance

Test range (DC V)	250V	500V	1000V
Measuring Ranges	0-200M Ω		0-2000M Ω
Resolution	1 count/100K Ω		1 count/1M Ω
Output Voltage on Open Circuit	Rated test Voltage +10%		
Output Current	1mA DC		
Power Consumption	Max. consumption current Approx. 250mA		
Accuracy	$\pm 1.5\%rdg \pm 5dgt$		$\pm (3\%rdg + 3dgt)$ (under 1G Ω /2000M Ω) $\pm (5\%rdg + 3dgt)$ (under 2G Ω /2000M Ω)

Continuity

Measuring Ranges	0-20 Ω	0-2k Ω
Resolution	0.01 Ω	1 Ω
Accuracy	$\pm (1.5\%rdg + 5dgt)$	$\pm (1.5\%rdg + 3dgt)$
Buzzer Sound Below	Under 10 Ω	—
Open Circuit Terminal Voltage	4V DC min	
Short Circuit Terminal Current	210mA DC min.	
Power Consumption	Max. consumption current approx. 160mA	

AC Voltage

AC Voltage Range	0-600V
Resolution	1V
Line Frequency Range	40-120Hz
Accuracy	$\pm (1.5\%rdg + 3dgt)$

General

Dimension	170(L) × 165(W) × 92(D)mm (with housing front cover)
Weight	1040g(battery included)
Power Source	1.5V(SUM-3) × 8 Type AA.
Accessories	Test leads (AL-24A) Fuse 1A 250V Instruction manual Batteries

● *This model is designed for telecoms.*



CE

1800 IN



CE

1801 IN

FEATURES

- High quality Taut Band movement.
- Battery operated.
- Solid state circuitry.
- Automatic circuit discharge.
- Color-coded scale.
- Three insulation test voltage.
- AC voltage measurement.
- Fuse protected.
- IEC 1010 CAT III 600V
- BS 16th edition.

Test Leads Connections

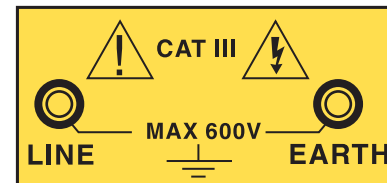

SPECIFICATIONS

Insulation Resistance	1800 IN			1801 IN		
Test Voltage (DC V)	250V	500V	1000V	50V	125V	250V
Measuring Ranges	0-100M Ω	0-200M Ω	0-400M Ω	0-20M Ω	0-50M Ω	0-100M Ω
Output Voltage Open Circuit	+10%			+10%		
Short Circuit Terminal Current	2mA DC			2mA DC		
Power Consumption	Max. consumption current Approx.190mA			Max. consumption current Approx.190mA		

Continuity	1800 IN	1801 IN
Measuring Ranges	0-50 Ω & ∞	0-50 Ω & ∞
Accuracy	$\pm 5\%$ of scale length	$\pm 5\%$ of scale length
Open Circuit Terminal Voltage	445mVDC .Approx.	445mVDC .Approx.
Short Circuit Terminal Current	145mADC .Approx.	145mADC .Approx.
Power Consumption	Max. consumption current Approx.200mA	Max. consumption current Approx.200mA

AC Voltage	1800 IN	1801 IN
AC Voltage Range	0-600V AC	0-600V AC
Accuracy	$\pm 2.5\%$ of full scale	$\pm 2.5\%$ of full scale
Line Frequency Range	40-1K Hz	40-1K Hz

General	1800 IN	1801 IN
Dimension (with housing front cover)	170(L) \times 165(W) \times 92(D) mm	170(L) \times 165(W) \times 92(D) mm
Weight (Battery Included)	Approx. 970g	Approx. 970g
Power Source	1.5V(SUM-3) x 8	1.5V(SUM-3) x 8
Accessories	Test leads (AL-24A) Fuse 1A. 250V \times 1 Instruction manual Shoulder belt Batteries	Test leads (AL-24A) Fuse 1A.250V \times 1 Instruction manual Shoulder belt Batteries



STANDARD

ANALOG INSULATION TESTER



CE

1832 IN

FEATURES

- High quality Taut Band movement.
- Three insulation test voltage (DC): 250V, 500V, 1000V.
- Two continuity test on low ohms: 500Ω & 3Ω.
- Small and lightweight, all in one case (do not need bag).
- AC voltmeter with linear scale up to 600 Vac.
- 200mA continuity short circuit current.
- 1mA test current on insulation test at nominal voltage.
- Automatic discharge of capacitance and inductive circuit off charge stored in the circuit under test.
- Live warning and display of external voltage presence.
- Fuse, air gap, crowbar and overload protected.
- On line battery monitoring shows if battery is ok.
- Very low battery consumption.
- On-Load battery check (+/- 205mA load for worst case).
- Mirror scale.
- Push and turn locking switch for long and hand free testing.
- IEC 1010-1 CAT III 600V
- BS 16th edition.

SPECIFICATIONS

Insulation Resistance

Test Voltage (DC V)	250V	500V	1000V
Output Voltage on open circuit	Rated test Voltage +10%		
Measuring Ranges	0-100MΩ	0-200MΩ	0-400MΩ
Mid-Scale Valve	1MΩ	2MΩ	4MΩ
Scale Multiplier	×1/2	×1	×2
Accuracy	±3% of indicated valve		
Output Short-Circuit Current	1.3mA		

Continuity

Measuring Ranges	3Ω /500Ω
Output Short-Circuit Current	≥210mA
Accuracy	±1.5% of scale length

AC Voltage

AC Voltage Range	0-600V AC
Accuracy	± 3% of scale length

General

Voltage Warning	Warning light circuit live lit From 90Vdc/70Vac Buzzer beep from 24Vac/dc
Battery Check	Battery check indicate good batteries from 8Vdc to 13Vdc during a load test of 205mA
Battery OK	Battery OK Led from 8Vdc and is operative while testing
Power Source	1.5V(SUM-3) ×8. Type AA.
Dimension	170(L)×165(W)×92(D)mm (with housing front cover)
Weight	1.1kg(battery included)
Accessories	Test leads (AL-24A) Fuse 0.5A 250V Shoulder belt Instruction manual Batteries



Test Leads Connections

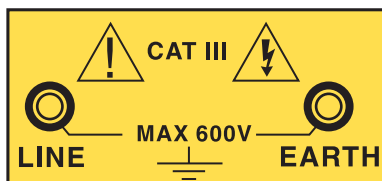

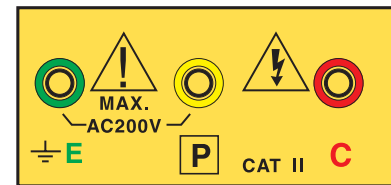

CE
Test Leads Connections

1820 ER
FEATURES

- Capable of measuring earth voltage (Vac).
- 2mA measuring current permits the testing of earth resistance without tripping earth leakage current circuit breakers in the circuit.
- In addition to the facility for precision measurement, test leads for simplified two wire measuring system are also supplied as standard accessories.
- Data hold function.
- Battery operated.
- EN/IEC 61010-1 CAT II 300V
- **Calibration performed with supplied test leads.**

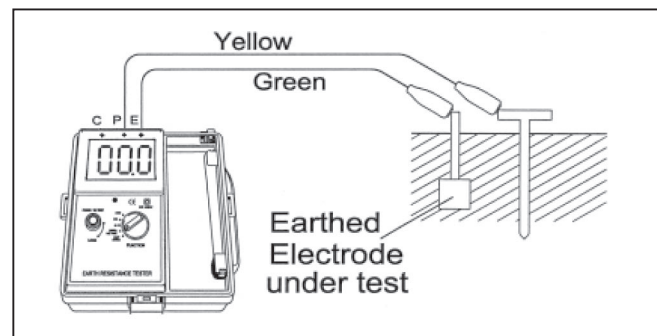
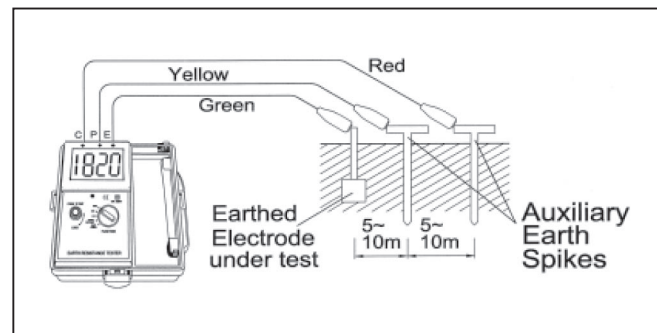
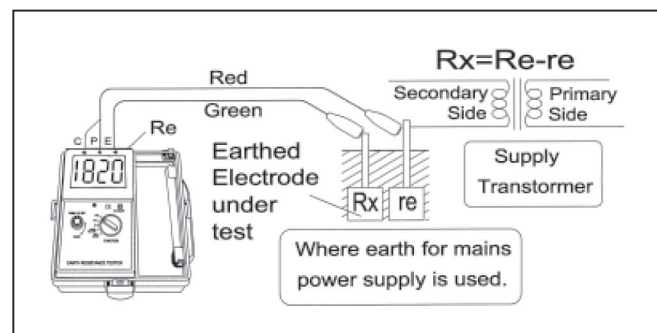
SPECIFICATIONS

Measuring Ranges	Earth Resistance 0-20Ω/0-200Ω/0-2000Ω Earth Voltage 0-200V AC (40-500Hz)
Accuracy	Earth Resistance ± (2% rdg+2dgt) Earth Voltage ± (1% rdg+2dgt)
Earth Resistance Resolution	0-20Ω (0.01Ω) 0-200Ω (0.1Ω) 0-2KΩ (1Ω)
Measuring System	Earth Resistance by constant current inverter 820Hz approx. 2mA.
Low Battery Indication	" " symbol appears on the display
Data Hold Indication	" " symbol appears on the display
Over Range Indication	"1" (MSD)
Open Circuit Indication	LED will be unlit
Display	LCD 3½ digit(2000 counts)
Power Source	(R6P)1.5V×8. Type AA
Dimensions	170(L)×165(W)×92(D)mm
Weight	Approx.1000g(battery included)
Accessories	Test leads (AL-36: red-15m yellow-10m green -5m +AL-33) Auxiliary earth spikes. Simplified measurement probe Shoulder belt Instruction manual Batteries

Earth Voltage Measurement

Earth Resistance Measurement

Earth Resistance Measurement



1805 ER

WHY "GROUNDING TEST" IS NECESSARY ?

"Grounding" has a few different purposes, such as the safety and stability of the electrical circuits. Listed below are more info about it.

1. Power system to the ground:

The purpose is preventing the secondary side from the damage of the primary side. It's necessary for users' safety.

2. Equipment to the ground:

Connect equipments or shells to the ground. The purpose is protecting human being from the leakage of the equipments.

3. Electrical signal to the ground:

Set up a "Zero volt " reference point or a loop path for all different signals. The purpose is for the correct operation of measuring and safety device.

4. Grounding for shielding:

To prevent static electricity.

To prevent noise, electromagnetic interference (put shielding).

Application: shielding room, cable and communication wires to the ground, Equipments' guard terminals to the ground, power transformers and filters to the ground.

FEATURES

- High quality Taut Band movement.
- Capable of measuring earth voltage(Vac).
- 2mA measuring current permits the testing of earth resistance without tripping earth leakage current circuit breakers in the circuit under test.
- In addition to the facility for precision measurement, test leads for simplified two wire measuring system also supplied as standard accessories.
- Battery operated.
- Battery test indication.
- EN/IEC 61010-1 CAT III 150V
- *Calibration performed with supplied test leads.*

SPECIFICATIONS

Measuring Ranges	Earth Resistance 0-10Ω/0-100Ω/0-1000Ω Earth Voltage 0-30V AC (40-500Hz)
Accuracy	Earth Resistance ± 3% of full scale Earth Voltage ± 2.5% of full scale
Measuring System	Earth Resistance by constant current inverter. 820Hz, approx. 2mA.
Open Circuit Indication	LED unlit
Power Source	1.5V(R6P)×8
Dimensions	170(L)×165(W)×92(D)mm
Weight	Approx.1000g(battery included)
Accessories	Test leads (AL-36: red-15m yellow -10m green -5m +AL-33) Auxiliary earth spikes. Simplified measurement probe. Heavy-duty case Shoulder belt Instruction manual Batteries

Test Leads Connections

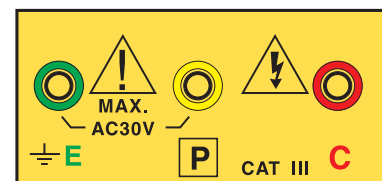



STANDARD

DIGITAL ELCB TESTER

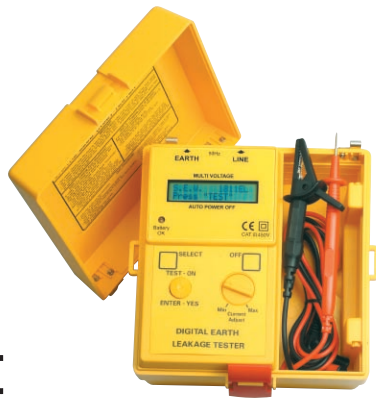

CE

1811 EL

FEATURES

- 2 Lines x 16 Characters L.C.D.
- Very Low Consumption.
- Microprocessor Controlled.
- Suitable for industrial applications.
- Better than 3% accuracy (Current).
- Menu Driven.
- Accurate Digital readout of Disconnection Time.
- Accurate Digital readout of Disconnection Sensitivity.
- Data Hold function.
- Zero Crossing Circuitry permits testing at 0° or 180° .
- Disconnection Phase Polarity Shown on L.C.D display.
- Auto-Off and Off override.
- Polarity Trip indicator (Positive or Negative Phase).
- EN/IEC 61010-1 CAT III 450V

SPECIFICATIONS

Current Settings	0-999mAac/50Hz
Current Selection	Knob
Phase Start Selection	Referenced to Earth
0°and 180°	Yes
Over-Temperature Protection	Yes
Phase Polarity Trip Indicator	Referenced to Earth
Yes	Yes
Operating Voltage (L-E)	110 Vac to 450 Vac
Timer Resolution	1ms (Max Time=99 .999S)
Timer Accuracy	1ms ±1ms
Current Accuracy	±1% ±1mA
Current Resolution	1mA
Voltmeter Accuracy(50Hz)	50-350 Vac=±2%±1V 350-450 Vac=±5%±1V
Voltmeter Resolution	1V
Operating Temperature	- 5°C to 40°C
Storage Temperature	- 10°C to 85°C
Power Source	8 x AA Batteries Bat OK Led lit if > 7.5V
Maximum Current Specified at	450 Vac/50Hz
Dimensions	170(L) x 165(W) x 92(D)mm
Weight	Approx. 1180 g (battery included)
Accessories	Test leads Shoulder belt Instruction manual Batteries

Test Leads Connections

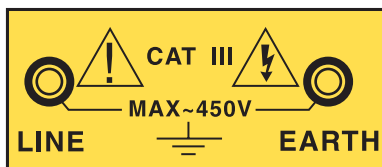

CE

1812 EL

FEATURES

- 2 Lines x 16 Characters L.C.D.
- Very Low Consumption.
- Microprocessor Controlled.
- Menu Driven.
- Accurate Digital readout of Disconnection Time.
- Automatic data hold function.
- Zero Crossing Circuitry permit testing at 0° or 180° .
- Disconnection Phase Polarity Shown on L.C.D display.
- Auto-Off and Off override.
- Polarity Trip indicator (Positive or Negative Phase).
- Wiring polarity indicator.
- Measure voltage and frequency between Line and Earth before testing.
- EN 61010-1 CAT III 240V

SPECIFICATIONS

Current Settings	3mA, 5mA, 7mA, 10mA,15mA, 20mA, 30mA, 35mA,50mA, 100mA, 125mA,150mA, 175mA, 250mA,300mA, 375mA, 500mA.
Current Selection	Rotary switch selector
Phase Start Selection	Referenced to Earth
0°and 180°	Yes
Over-Temperature Protection	Yes (3 sensors)
Wiring Correctness Indication	Yes (LEDs)
Trip Indicator	Yes (LCD)
Phase Polarity Trip Indicator	Yes (LCD)
Referenced to Earth	Referenced to Earth
Operating Voltage (L-E)	1812EL-A 240Vac 1812EL-B 230Vac 1812EL-C 220Vac 1812EL-D 110Vac
Voltmeter (L-E)	20Vac-280Vac
Timer Resolution	1mS (Max time=2.999S)
Timer Accuracy	1mS ±1mS
Current Accuracy	±5% ±1mA
Voltmeter Resolution	1Vac
Voltmeter Accuracy	±2%±1Vac
Operating Temperature	- 5°C to 45°C
Storage Temperature	- 10°C to 85°C
Power Source	8 x AA Batteries Bat OK Led = Vbat > 7.5V Measure battery voltage at start up
Dimensions	170(L) x 165(W) x 92(D)mm
Weight	Approx. 1020 g (battery included)
Accessories	Test leads Shoulder belt Instruction manual Batteries

Test Leads Connections

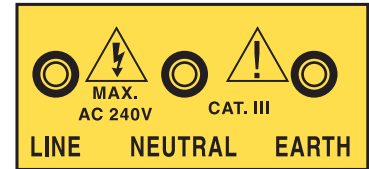

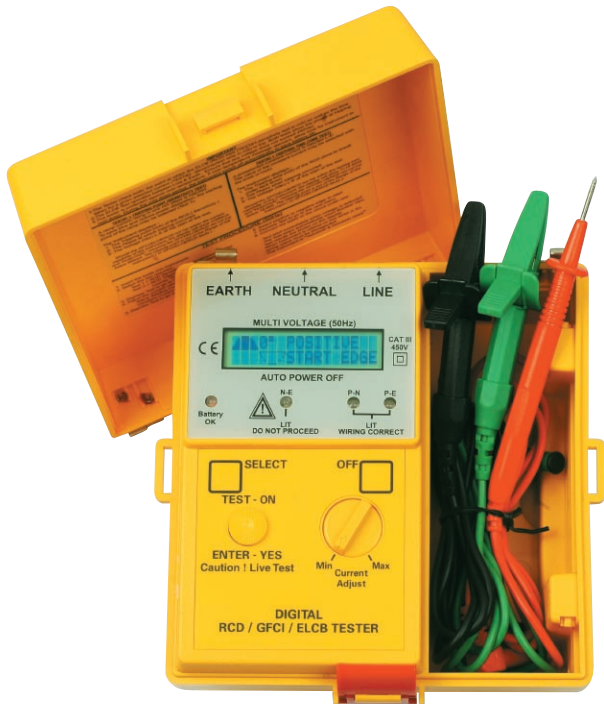

1813 EL

FEATURES

- 2 Lines x 16 Characters L.C.D.
- Very low consumption.
- Microprocessor controlled.
- Suitable for domestic version.
- Better than 3% accuracy (current).
- Menu driven.
- Accurate digital readout of disconnection time.
- Accurate digital readout of disconnection sensitivity.
- Automatic Data Hold function.
- Zero crossing circuitry permits testing at 0° or 180°.
- Disconnection phase polarity shown on LCD display.
- Auto-Off and Off override.
- Polarity trip indicator (positive or negative phase)
- Wiring polarity indicator.
- Measures voltage between Line and Earth before testing.
- 60 Hz available.

SPECIFICATIONS

System Voltage(50Hz/60Hz)	550 V 380 V 240 V
Current Settings	2-999mA ac
Current Selection	Knob
Phase Start Selection Referenced to Earth	0° and 180°
Over-Temperature Protection	Yes
Wiring Correction Indication	Yes
Phase Polarity Trip Indicator	Yes
Operating Voltage (L- E)	110 Vac to 317 Vac
Timer Resolution	1ms (Max Time=19.999s)
Timer Accuracy	1ms ± 1ms
Current Accuracy	±1% ±1mA
Current Resolution	1mA
Voltmeter Accuracy(50Hz)	50-350 Vac:±2%±1V 350-450 Vac:±5%±1V
Voltmeter Resolution	1V
Operating Temperature	-5°C to 45°C
Storage Temperature	-10°C to 85°C
Dimensions	170(L)×165(W)×92(D)mm
Weight	Approx.1300g(battery included)
Power Source	1.5V(AA)×8 Batteries Bat OK Led=Vbat > 7.5V
Accessories	Test leads Shoulder belt Instruction manual Batteries

CONNECTIONS

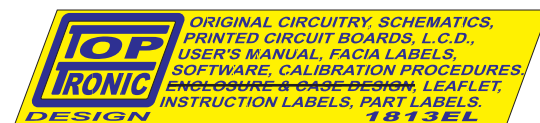
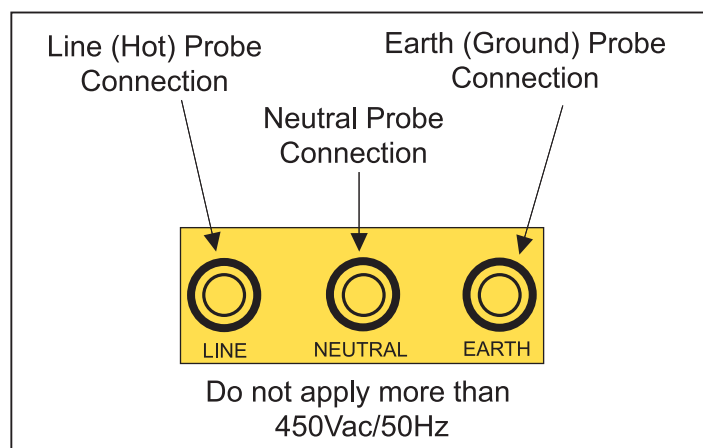

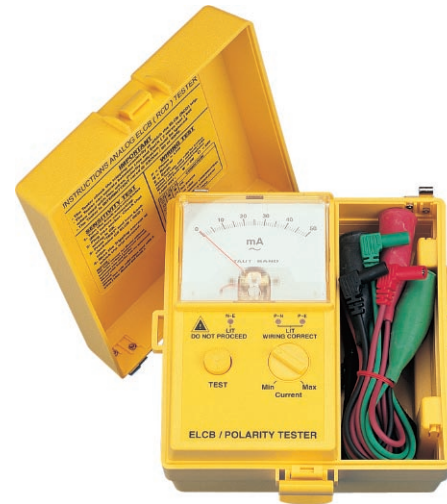
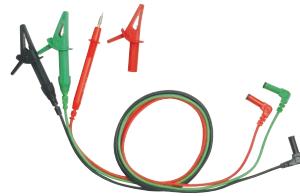

CE

810 EL

1810 EL
TEST LEADS

FEATURES

- No battery.
- Simple operation.
- Wiring check.
- Robust.
- Can be used on 2 wires L-E (ELCB/RCCB/GFCI tester).
- Can be used on 3 wires L-E-N (with wiring check).
- Sense automatically 50 or 60 Hz.
- Current injected in phase with the voltage.
- Fused.
- Wide operating voltage (195Vac to 265 Vac).
- Other voltage optional (110V).
- EN/IEC 1010-1 CAT III 265V

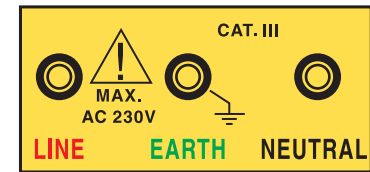
SPECIFICATIONS

Wiring Check LEDs	Line-Neutral=Green Line-Earth=Green Neutral-Earth=Red
Current Settings	10-50mA @ 230Vac
Current Selection	Knob
Frequency of Operation	50/60 Hz Sinusoidal
Over-Temperature Protection	Yes by NTC sensor Test stopped indication by Red Led.
Operating Voltage (L-E)	230 Vac ±15%
Meter Accuracy	±3% of full scale
Operating Temperature	-5°C to 45°C
Storage Temperature	-10°C to 85°C
Dimensions	150(L) x 73(W) x 50(D)mm
Weight	220g Approx.
Accessories	Test leads Instruction manual

Test Leads Connections

FEATURES

- Taut Band movement.
- Simple operation.
- Wiring check.
- Robust.
- Can be used on 2 wires L-E (ELCB/RCCB/GFCI tester).
- Can be used on 3 wires L-E-N (with wiring check).
- No batteries.
- Sense automatically 50 or 60Hz.
- Current injected in phase with the voltage.
- Other voltage optional (110V).
- EN 50081-1 EN50082-1

SPECIFICATIONS

Current Settings	10-50mA @ 230Vac
Current Selection	Knob
Frequency of Operation	50/60 Hz Sinusoidal
Over-Temperature Protection	NO
Operating Voltage (L-E)	230 Vac ±15%
Meter Accuracy	±1% of full scale
Protection	Fused (200mA 250V)
Operating Temperature	-5°C to 45°C
Storage Temperature	-10°C to 85°C
Battery	None
Dimensions	170(L) x 165(W) x 92(D)mm
Weight	730g Approx.
Accessories	Test leads Shoulder belt Instruction manual





1824 LP

FEATURES

- Measures Earth Resistance without the need for poles in the ground or external measuring wires.
- Earth Measurement uses the real earth current path and the current generated by the electric network, without the need for any disconnection.
- Earth Resistance displays is exactly what the earth resistance, that the earth current will need to go through is an earth fault occurs. (you do not need to add all the bonding points and connection paths)
- Displays voltage supply at the transformer (Line to Neutral), without loading the transformer.
- Single One Smart Push button operation ;ON, Scroll through results and menus.
- Checks wiring integrity(LEDs).
- Auto-off/auto-ranging (software range).
- Microprocessor controlled.
- Combined Prospective Short circuit Current, Loop and Earth Tester.
- Loop test for L-E and PSC between L-N.
- Voltage test L-N.
- Display can be customized for large orders.
- EN/IEC 61010-1 CAT III 300V



The 1824LP is the first of a new generation of instruments for the testing of electrical installations.

It has a **built-in Earth tester** which does not requires the use of poles or long wires. **This instrument is useful for fault-finding or commissioning of electrical installations.** This new instrument uses a three wires unique principle of operation. It display the main **system voltage** of the power utility, without loading the wiring. The 1824LP displays the **Loop Impedance** between Line and Earth ($Z_L + Z_E = Z_{L-E}$) and **Prospective Short Circuit** between Line and Neutral.

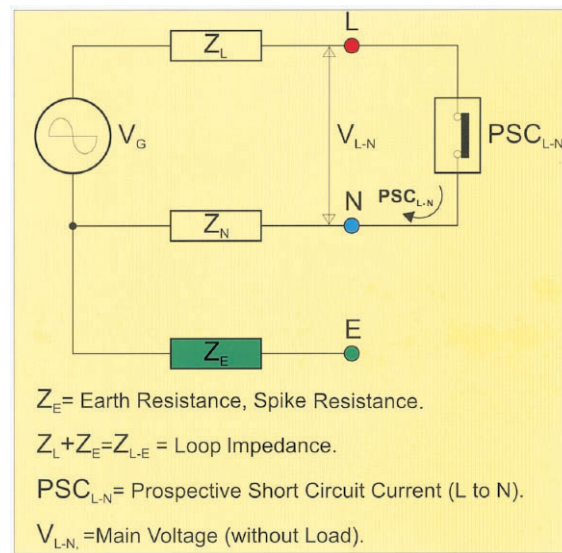

SPECIFICATIONS

Loop Impedance Range L- E	0.03-2000 Ω (Software Ctrl)
Test Currents In Each Loop	11.76A at 230V/50Hz
Voltage Measurement	50 to 280V AC (Sine)
Earth wire/path Return Resistance	0.01-2000 Ω (Software Ctrl)
Neutral Wire Resistance	(Not available, see 1826NA)
Line Wire Resistance & Transformer Windings	(Not available, see 1826NA)
PSC Current (L -N) Max	8kA at 230Vac supply
PSC Current (L -E) Max	(Not available, see 1826NA)
Operating Voltage	230V \pm 20 at 50Hz Sine
Typical Accuracy	
Loop Impedance	4%rdg \pm 2dgt
PSC Current	10%rdg \pm 5dgt
Voltage	2%rdg \pm 1dgt
Operating -Temperature -Humidity	-10 $^{\circ}$ C to +40 $^{\circ}$ C 80% max relative humidity
Dimensions (LxWxD)	(170x165x92)mm
Weight	970g Approx.
Power Source	1.5V(AA)x8 Batteries
Accessories	Test leads (AL-34) Shoulder belt Instruction manual Batteries



STANDARD

DIGITAL LOOP/PSC/LOAD TESTER

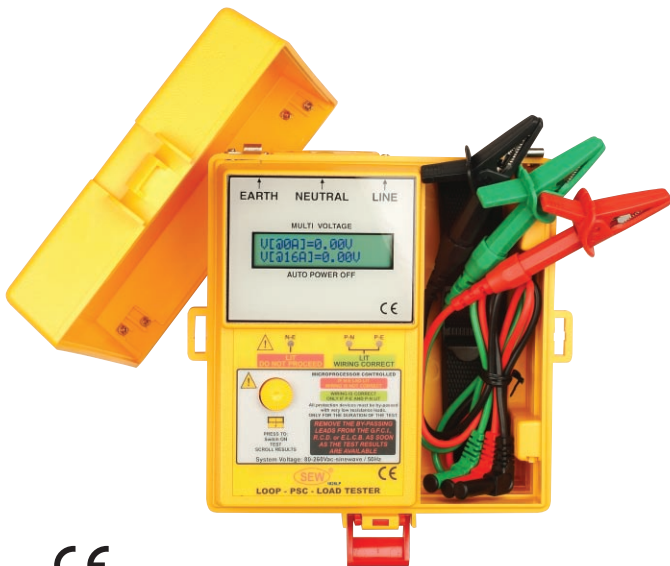

CE

1825 LP

FEATURES

- Measures the volt drop as if 16A is flowing between Line and Neutral.
- Displays voltage without current (V at 0A).
- Displays voltage as if 16A is flowing between Line and Neutral (V at 16A).
- Loop test for L-E
- PSC between L-N.
- Single One Smart Push button operation; ON, Scroll through Results and menus.
- Checks wiring integrity (LEDs).
- Auto-off/auto-ranging (software range).
- Microprocessor controlled.
- Combined Prospective Short circuit Current, Loop and Load Tester.
- Display can be customized for large orders.
- EN/IEC 61010-1 CAT III 300V

Test Leads Connections

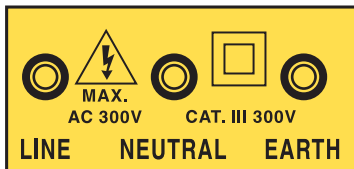

1825LP is the instrument which displays the main **system voltage** (V at 0A) of the power utility and calculates the **volt drop** between Line and Neutral as if 16A is flowing between Line to Neutral.

1825LP displays the system voltage minus the voltage losses into the Line and Neutral impedances (losses due to the current circulating into these impedances).

The result of this dropped **voltage is displayed as if you had a 16A load** (V at 16A).

This instrument is useful for fault-finding or commissioning of electrical installations.

This new instrument uses a three wires unique principle of operation. 1825LP displays **Loop Impedance** between Line and Earth ($Z_L + Z_E = Z_{L-E}$) and **Prospective Short Circuit** between Line and Neutral.

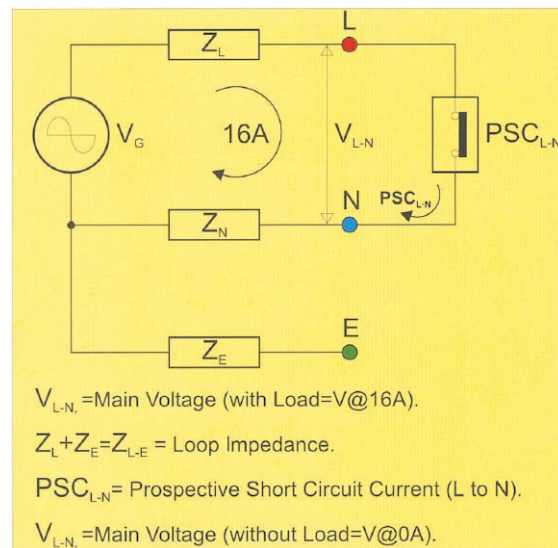

SPECIFICATIONS

Loop Impedance Range L - E	0.03-2000 Ω (Software Ctrl)
Test Currents in Each Loop	11.76A at 230V/50Hz
Voltage Measurement L - N	50 to 280V AC (Sine)
Load Current for Volt Drop (L-N)	16A (Calculation)
Neutral Wire Resistance	(Not available, see 1826NA)
Line Wire Resistance & Transformer Windings	(Not available, see 1826NA)
PSC Current (L-N) Max	8 kA at 230Vac supply
PSC Current (L-E) Max	(Not available, see 1826NA)
Operating Voltage	230V \pm 20 at 50Hz Sine
Typical Accuracy	
Loop Impedance	5%rdg \pm 2dgt
PSC Current	12%rdg \pm 5dgt
Voltage	3%rdg \pm 1dgt
Operating - Temperature - Humidity	-10 $^{\circ}$ C to + 40 $^{\circ}$ C 80% max relative humidity
Dimensions (LxWxD)	(170x165x92)mm
Weight	970g Approx.
Power Source	1.5V(AA)x8 Batteries
Accessories	Test leads (AL-34) Shoulder belt Instruction manual Batteries

CE

1826 NA

FEATURES

- Measures Earth Resistance without the need for poles in the ground or external measuring wires.
- Earth Measurement uses the real earth current path and the current generated by the electric network, without the need for any disconnection.
- The Earth Resistance displayed is exactly the earth resistance, that the earth current will need to go through is an earth fault occurs. (you do not need to add all the bonding points and connection paths resistances)
- Displays voltage supply at the transformer (Line to Neutral), without loading the transformer. Displays voltage between Line (Phase) and Earth (Ground), without drawing any current.
- Measures the Impedance of the Line itself, so you can analyzes and differentiate between the multiples paths of the wiring.
- Measures the Neutral Impedance. Single One Smart Push button operation; ON, Test, Scroll trough results and menus.
- Checks wiring integrity(LEDs).
- Auto-off/auto-ranging (software ranging). Microprocessor controlled.
- Combined Prospective Short circuit Current, Loop, individual wire and Earth Tester.
- Voltage test L-N and L-E.
- Loop test for L-E and L-N and PSC.
- Enables analysis of constituent components in L-E and L-N loops giving resistance of earth, neutral wire, live wire and transformer winding.
- The display can be customized for large orders.
- EN/IEC 61010-1 CAT III 300V



The 1826NA is the first portable electrical network analyzer. It is a built-in Earth tester which does not require the use of poles or long wires. **This instrument is useful for fault-finding or commissioning of electrical installations.** Differentiation between the Line (hot), Neutral and Earth (ground) path by reading their values has never been so easy. Bad contacts, old wiring or bad earth path are quickly identified. Faulty electrical network can be resolved in a fraction of the time normally required using conventional equipment. Down time due to a faulty electrical network is minimal as the fault can be identified and diagnosed quickly. Find which wire need to be attended to and why (find those old wires with high impedance before a fire starts, and replace them). **The complete electrical network can be analyzed by scrolling through the results.**

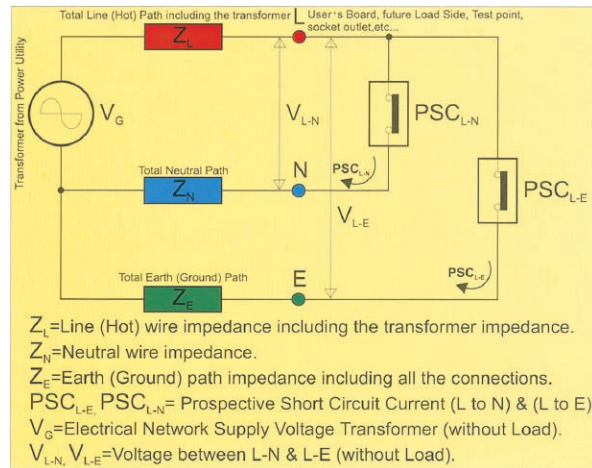

SPECIFICATIONS

Loop Impedance Range L - E, L - N	0.03-2000 Ω (Software Ctrl)
Test Currents in Each Loop	11.76A at 230V/50Hz
Voltage Measurement L - N, L - E	50 to 280V AC (Sine)
Earth wire/path Return Resistance	0.01 -2000 Ω (Software Ctrl)
Neutral Wire Resistance	0.01 -2000 Ω (Software Ctrl)
Line Wire Resistance & Transformer Windings	0.01 -2000 Ω (Software Ctrl)
PSC Current (L - N) Max	6kA at 230Vac supply
PSC Current (L - E) Max	6kA at 230Vac supply
Operating Voltage	230V \pm 20 at 50Hz Sine
Typical Accuracy	
Loop Impedance	4%rdg \pm 2dgt
PSC Current	10%rdg \pm 5dgt
Voltage	2%rdg \pm 1dgt
Operating - Temperature - Humidity	-10 $^{\circ}$ C to +40 $^{\circ}$ C 80% max relative humidity
Dimensions (LxWxD)	(170x165x92)mm
Weight	970g Approx.
Power Source	1.5V(AA)x8 Batteries
Accessories	Test leads (AL-34) Shoulder belt Instruction manual Batteries



CE

2120 ER

CE

2105 ER
FEATURES

- Capable of measuring earth voltage.
- 2mA measuring current permits the testing of earth resistance without tripping earth leakage current circuit breakers in the circuit under test.
- In addition to facilitating for precision measurement, test leads for simplified two-wire measuring system also are supplied as standard accessories.
- 0Ω adjustment.
- Data hold function.
- Battery operated.
- Battery life indicator.
- Designed to meet IEC/EN 61010-1 CAT III 200V.
- **Calibration performed with supplied test leads.**

SPECIFICATIONS

Measuring Ranges	Earth Resistance 0-20Ω/0-200Ω /0-2000Ω Earth Voltage 0-200V AC (40-500Hz)
Accuracy	Earth Resistance ±(2% rdg+2dgt) or ±0.1Ω, which is grater Earth Voltage ±(1% rdg+2dgt)
Earth Resistance Resolution	0-20 Ω (0.01 Ω) 0-200 Ω (0.1 Ω) 0-2000 Ω (1 Ω)
Measuring System	Earth Resistance by constant current inverter 820Hz approx. 2mA.
Display	LCD 3-1/2digit (2000 counts)
Open Circuit Indication	LED will be unlit
Low Battery Indication	"" symbol appears on the display
Data Hold Indication	"" symbol appears on the display
Over Range Indication	"1" (MSD)
Power Source	1.5V SUM-3 (R6P) x 8. or equivalent
Dimensions	210(L) x 210(W) x 100(D)mm
Weight	Approx.1395g (battery included)
Accessories	Test leads (AL-36 : red-15m , yellow-10m , green-5m) Simplified measurement probe. Auxiliary earth spikes. Shoulder belt. Instruction manual. Batteries.

FEATURES

- Capable of measuring earth voltage.
- 2mA measuring current permits the testing of earth resistance without tripping earth leakage current circuit breakers in the circuit under test.
- In addition to facilitating for precision measurement, test leads for simplified two-wire measuring system also are supplied as standard accessories.
- Battery operated.
- Battery test indicator.
- Designed to meet IEC/EN 61010-1 CAT III 30V.
- **Calibration performed with supplied test leads.**

SPECIFICATIONS

Measuring Ranges	Earth Resistance 0-12Ω0-120Ω/0-1200Ω Earth Voltage 0-30V ac (40-500Hz)
Accuracy	Earth Resistance ±3% of full scale Earth Voltage ±2.5% of full scal
Measuring System	Earth resistance by constant current inverter(Square Signal) 820Hz approx. 2mA
Power Source	1.5V SUM-3 (R6P) x 8 or equivalent
Dimensions	210(L) x 210(W) x 100(D)mm
Weight	Approx.1370g (battery included)
Accessories	Test leads (AL-36 : red-15m , yellow-10m , green-5m) Simplified measurement probe. Auxiliary earth spikes. Shoulder belt. Instruction manual. Batteries.



CE

FEATURES

- 68mm x 34mm (1.338" x 2.677") large LCD display.
- Three insulation test voltages(DC) : 250V, 500V, 1000Vdc.
- External voltage warning indication.
- Automatic circuit discharge.
- Test insulation at rated voltage into a 1mA load.
- 200mA continuity short circuit test current.
- AC voltage measurement.
- Fuse protection.
- Timer for test function (count 3~5 minutes).
- Data hold function.
- Auto power off function.
- EN/IEC 61010-1 CAT III 600V
- BS 16th edition



2751 IN

SPECIFICATIONS

Insulation Resistance

Test Voltage (DCV)	250V/500V/1000V
Measuring Ranges (Auto)	0-20 / 0-200 / 0-2000MΩ
Output Voltage Open Circuit	+10%
Accuracy	20MΩ : ± (1.5%rdg +5dgt) 200MΩ : ± (2.5%rdg +3dgt) 2000MΩ : ± (5%rdg +5dgt)
Output Current	1mA DC min. At 0.25MΩ (250V range) 1mA DC min. At 0.5MΩ (500V range) 1mA DC min. At 1MΩ (1000V range)
Power Consumption	Max. Consumption current approximately 250mA

AC Voltage

Measuring Ranges	0 ~ 600V
Resolution	1V
Line Frequency Range	40 ~ 120Hz
Accuracy	± (1.5%rdg +3dgt)

Continuity

Measuring Ranges (Auto)	0-20 / 0-200 / 0-2000Ω
Accuracy	± (1.5%rdg +3dgt)
Open Circuit Terminal Voltage	4Vdc min.
Short Circuit Terminal Current	200mAdc min.
Power Consumption	Max. Consumption current approximately 160mA
Buzzer Sounds	Under 10Ω

General

Display	LCD 3½ (2000 counts)
Dimensions	205(L) x 90(W) x 55(D)mm
Weight	Approx. 550g (battery included)
Power Source	1.5V SUM-3 (R6P) x 6 or equivalent
Accessories	Test leads (TEL-AL11-A) Fuse (0.5A, 250V) Heavy-duty case Instruction manual Batteries



CE

2732 IN
FEATURES

- High quality Taut Band movement.
- Three insulation test voltage :
 1. 250Vdc - 100MΩ
 2. 500Vdc - 200MΩ
 3. 1000Vdc - 400MΩ
- Two Continuity Test on "Low Ohms".
 1. 500Ω
 2. 3Ω
- Small and Lightweight, "all in one" case (do not need bag).
- AC voltmeter with linear scale up to 600Vac.
- 200mA continuity short circuit test current.
- 1mA test current on insulation test at nominal voltage.
- Automatic discharge of capacitance and inductive circuit off charge stored in the circuit under test.
- Live Warning and display of external voltage presence.
- Fuse, air gap, crowbar and overload protected.
- On line battery monitoring shows if battery is ok.
- Very low battery consumption.
- On-load battery check (+/- 205mA load for worst case).
- Operates on 6 dry batteries AA, R6P type.
- Mirror scale.
- Push and Turn locking switch for long and hand free testing.
- IEC/EN 61010-1 CAT III 600V

SPECIFICATIONS
Insulation Resistance

Test Voltage (DCV)	250V	500V	1000V
Output Voltage Open Circuit	+10%		
Measuring Ranges	0 ~ 100MΩ	0 ~ 200MΩ	0 ~ 400MΩ
Mid-scale Valve	1MΩ	2MΩ	4MΩ
Scale Multiplier	x1/2	x1	x2
Accuracy	± 5% of full scale		
Output Current	±1.3mA		

Continuity

Measuring Ranges	3 / 500Ω
Output Short-Circuit Current	≥ 210mA
Accuracy	±1% of scale length

AC Voltage

Measuring Ranges	0 ~ 600V
Accuracy	±3% of scale length

General

Voltage Warning	Warning light circuit live lit from 90Vac / 70Vac buzzer beep from 24Vac /dc.
Battery Check	Battery check indicate good batteries from 8Vdc to 13Vdc during a load test of 205mA. Battery ok : battery ok led lit from 6.5Vdc and is operative while testing.
Dimensions	205(L) x 90(W) x 55(D)mm
Weight	Approx. 550g (battery included)
Power Source	1.5V SUM-3 (R6P) x 6 or equivalent
Accessories	Test leads (TEL-AL11-A) Fuse (0.5A, 250V) Heavy-duty case Instruction manual Batteries

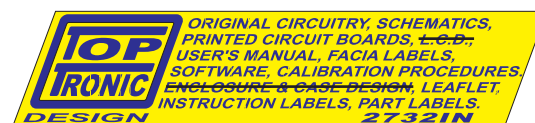
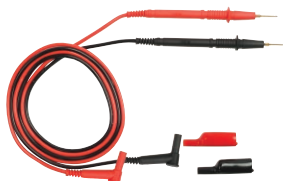
Test leads

FEATURES



- Capable of measuring earth voltage.
- 2mA measuring current permits the testing of earth resistance without tripping earth leakage current circuit breakers in the circuit under test.
- In addition to the facility for precision measurement, test leads for simplified two-wire measuring system are also supplied as standard accessories.
- Data hold function.
- Battery operated.
- Battery test indicator.
- Timer for test function(count 3~5 minutes).
- IEC/EN 61010-1 CAT III 200V
- **Calibration performed with supplied test leads.**



CE

2720 ER
Test leads

SPECIFICATIONS

Measuring Ranges	Earth Resistance 0-20 / 0-200 / 0-2000Ω Earth Voltage 0-200 Vac
Accuracy	Earth Resistance ± (2% rdg+2dgt) Earth Voltage ± (1% rdg+2dgt)
Earth Resistance Resolution	0~20Ω (0.01Ω) 0~200Ω (0.1Ω) 0~2000Ω (1Ω)
Measuring System	Earth resistance by constant current inverter 820Hz, 2mA approx.
Low Battery Indication	"  " Symbol appears on the display
Data Hold Indication	"  " Symbol appears on the display
Over Range Indication	"1" (MSD)
Display	LCD 3½ digit (2000 counts)
Dimensions	205(L) x 90 (W) x 55(D)mm
Weight	Approx. 550g (battery included)
Power Source	1.5V SUM-3 (R6P) x 6 or equivalent
Accessories	Test leads (AL-36:red-15m, yellow-10m, green-5m+AL-33) Auxiliary earth spikes Simplified measurement probe Heavy-duty case Instruction manual Batteries



Development in progress

2734 ER

FEATURES

- Measures earth resistance.
- Earth testing at 20, 200 and 2000Ω.
- Measures earth continuity.
- Determines soil resistivity.
- Indispensable when testing large earthing system where very low resistance is required.
- Clear & large L.C.D.
- Potential lead resistance, current lead resistance and noise checks.
- High noise rejection.
- Low battery indicator.
- Lightweight, robust & compact.
- Color coded test leads.
- Indicators show if reading may be invalid (R_p , R_c , and noise).
- High tolerance to spike resistance helps testing in urban areas.
- **Calibration performed with supplied test leads.**



AL-4WER

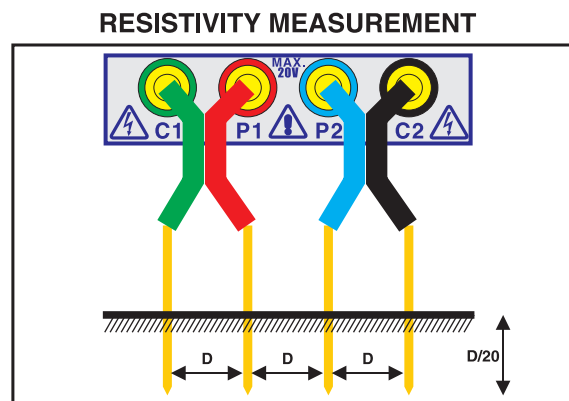
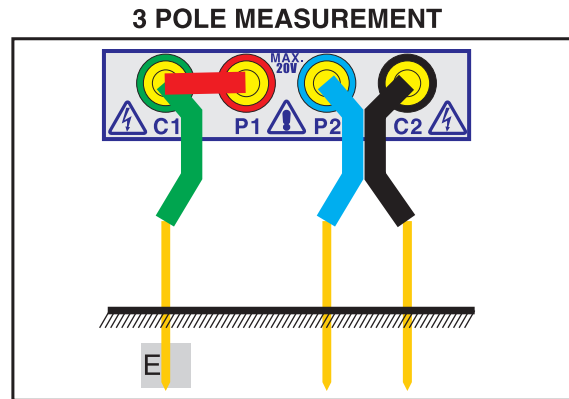

SPECIFICATIONS

Earth Resistance Ranges	0 to 20Ω in steps of 0.01Ω 0 to 200Ω in steps of 0.1Ω 0 to 2000Ω in steps of 1Ω
Accuracy	±2% rdg ±2 dgt Total service error ±5% rdg ±2 dgt
Test Current	10mA a.c. rms nominal on 20Ω range 1mA a.c. rms nominal on 200Ω range 0.1mA a.c. rms nominal on 2000Ω range
Test Frequency	128Hz ±1%
Interference	Interference voltage of 5V rms nominal 50/60Hz in the potential circuit will not affect the reading by more than ±0.5%
Maximum Current Spike Resistance(R_c)	2kΩ typical on 20Ω range 5kΩ typical on 200Ω range 50kΩ typical on 2000Ω range
Maximum Current Spike Resistance(R_p)	2.2kΩ typical on 20Ω range 22kΩ typical on 200Ω range 50kΩ typical on 2000Ω range
Maximum Output Voltage (C1-C2)	30Vrms
Voltage (AC-sine) Detection	>1V
Accuracy of Voltage Detection	±1V
Battery Low Indication Point	<7Vdc
Operating Temperature	- 15°C to +55°C
Dimensions	250(L) x 190(W) x 110(D)mm
Weight	Approx. 550 g (battery included)
Accessories	Test Leads(green-50m, red-36m, blue-20m, black-3m) Auxiliary earth bars Instruction manual Carry case Batteries



CE

2705 ER
FEATURES

- Capable of measuring earth voltage.
- 2mA measuring current permits the testing of earth resistance without tripping earth leakage current circuit breakers in the circuit under test.
- In addition to the facility for precision measurement, test leads for simplified two wire measuring system also supplied as standard accessories.
- Battery operated.
- Battery check function.
- IEC/EN 61010-1 CAT III 30V
- **Calibration performed with supplied test leads.**

SPECIFICATIONS

Measuring Ranges	Earth Resistance 0-10 / 0-100 / 0-1000Ω Earth Voltage 0-30 Vac(40~500Hz)
Accuracy	Earth Resistance ± 3% of full scale Earth Voltage ± 2.5% of full scale
Measuring System	Earth resistance by constant current inverter 820Hz, 2mA approx.
Dimensions	205(L) x 90 (W) x 55(D)mm
Weight	Approx. 514g (battery included)
Power Source	1.5V SUM-3 (R6P) x 6 or equivalent
Accessories	Test leads (AL-36:red-15m, yellow-10m ,green-5m+AL-33) Auxiliary earth spikes Simplified measurement probe Heavy-duty case Instruction manual Batteries



CE

2706 IM
FEATURES

- True measurement of speaker systems actual impedance at 1kHz.
- Three test ranges (20Ω / 200Ω / 2000Ω) allow testing of home theater and commercial sound systems.
- Measure transformer impedances.
- Battery operation.
- Low battery indication.
- Data hold function.
- Timer function for continuous hands free operation. The timer can last about 3~5 minutes when users press TEST ON/OFF button.
- IEC/EN 61010-1 CAT III 100V

SPECIFICATIONS

Measuring Ranges	0-20 / 0-200 / 0-2000Ω
Test Frequency	1kHz
Accuracy	20Ω : ±2%rdg ±2dgt or ±0.1Ω ,which is greater 200Ω /2000Ω : ±2%rdg ±2dgt
Low Battery Indication	""/> " Symbol appears on the display
Data Hold Indication	""/> " Symbol appears on the display
Display	LCD 3½ digit (2000 counts)
Dimensions	205(L) x 90 (W) x 55(D)mm
Weight	Approx. 530g (battery included)
Power Source	1.5V SUM-3 (R6P) x 6 or equivalent
Accessories	Test leads (AL-24A) Heavy-duty case Instruction manual Batteries

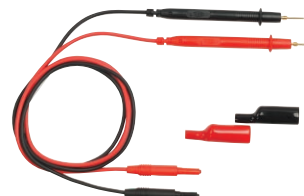
Test leads



2712 EL

The 2712 EL is a compact hand held residual current detector or earth leakage circuit breaker or ground fault circuit interrupter tester (designation could be different from country to country), designed to meet international standards of performance and safety. This model is quality instrument used by professionals to obtain accurate values of the protection disconnection time while a selectable fault current is injected to earth (ground).

FEATURES

- 2 lines x 16 characters L.C.D.
- Very low consumption.
- Microprocessor controlled.
- 50Hz and 60Hz operation.
- Menu driven.
- Accurate digital readout of disconnection time.
- Automatic data hold function.
- Over temperature protection.
- Over voltage protection.
- Fuse protection.
- Zero crossing circuitry permits testing at 0° or 180°.
- Disconnection phase polarity shown on LCD Display.
- Auto-off and off override.
- Polarity trip indicator (positive or negative phase).
- Wiring polarity indicator.
- Measures voltage between line and earth before testing.
- Frequency measurement indication.
- IEC/EN 61010-1 CAT III 300V

SPECIFICATIONS

Current Settings	3mA, 5mA, 7mA, 10mA, 15mA, 20mA, 30mA, 50mA, 100mA, 150mA, 250mA, 300mA, 500mA
Current Selection	Rotary switch selector
Phase Angle Setting	0° and 180° selectable
Operating Voltage (L-E) 50Hz or 60 Hz	Version A 240Vac Version B 230Vac Version C 220Vac Version D 110Vac
Voltmeter (L-E)	20Vac-280Vac (50Hz or 60Hz)
Over-Temperature Protection	Yes (3 sensors)
Wiring Correctness Indication	Yes (LEDs)
Trip Indicator	Yes (LCD)
Phase Polarity Trip Indicator	Yes (LCD) Referenced to Earth
Timer Resolution	1mS (max time=19.99S)
Timer Accuracy	±2mS
Current Accuracy	±5% ±1mA
Voltmeter Resolution	1Vac
Voltmeter Accuracy	±2% ±1Vac
Operating Temperature	-5°C to 45°C
Storage Temperature	-10°C to 85°C
Dimensions	205(L) x 90(W) x 55(D)mm
Weight	Approx. 530 g(battery included)
Power Source	1.5V SUM-3 (R6P) x 6 or equivalent
Accessories	Test leads Heavy-duty case Instruction manual Batteries

TEST LEADS

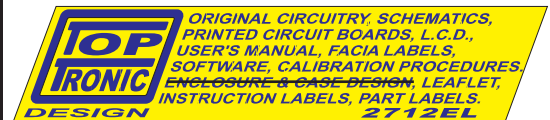
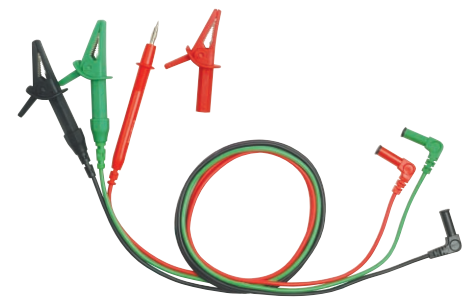



2713 PU

The high voltage proving unit for high voltage testers is utilized to determine if the devices under test are functionally working. The high voltage proving unit is not a calibrator and can't be utilized for calibration.

The high voltage proving unit for high voltage testers can be utilized to proof contact devices on a momentary basis (press on, check, release).

FEATURES

- Designed to proof :
 - phasing sticks.
 - high voltage detectors (contact type only, not to be used with non contact proximity detectors).
 - high voltage and voltage testers.
- Battery operated.
- Led indicates when power is "ON".
- Small and hand held.
- Quick connection with normal 4mm test leads.

SPECIFICATIONS

Voltage Settings (Internal Jumpers Selectable)	500 Vdc 1000 Vdc 2500 Vdc 5000 Vdc (default setting)
Over-Current Protection	Yes
Power on Indicator	Yes
Operating Temperature	-5 °C to 45 °C
Storage Temperature	-10 °C to 85 °C
Dimensions	205(L) x 90(W) x 55(D)mm
Weight	Approx. 510 g (battery included)
Power Source	1.5V SUM-3 (R6P) x 6 equivalent
Accessories	Test leads (AL-30AR+AL-30AB) Batteries

Proving second source equivalents or compatible models

The high voltage proving unit for voltage testers output a DC voltage of around 5000Vdc (factory setting).

This unit has been designed to deviate most of the voltage testers and the voltage detectors. It can be used with most of the phasing sticks and voltage testers which can accept 5000V input. This unit is basically a low current 5000Vdc supply. The output current is limited. To save battery life, it is recommended to depress the test button for short period of time only .

Proofing PC xxk - Multifunction Voltage Testers

The master pole must be connected to the positive socket of the proofing unit.

The slave pole must be connected to the negative socket of the proofing unit.

The test button of the proofing unit must be depressed for a short time only. During that short time, the neon voltage detector must lit and the panel meter must deviate and show increase in the voltage, then come back down.

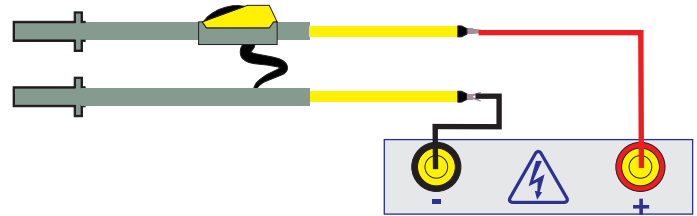

Proofing PC xxk - Voltage Testers

The master pole must be connected to the positive socket of the proofing unit.

The earth prod (or earth wire) must be connected to the negative socket of the proofing unit.

The test button of the proofing unit must be depressed for a short time only. During that short time, the neon voltage detector must lit and the panel meter must deviate and show increase in the voltage, then come back down.

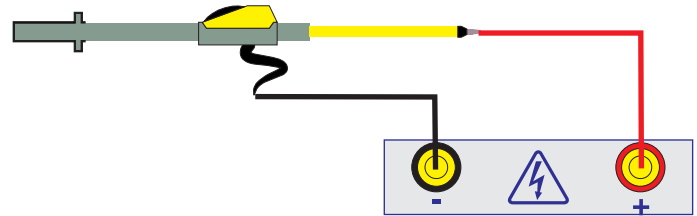



STANDARD

ELECTRICAL NETWORK ANALYZER



FEATURES

2726 NA

- Built-in earth tester.
- Built-in loop / psc tester.
0.03-2000Ω (software ctrl).
- Built-in voltmeter.
- Built-in wiring checker.
- One push button smart control.
- Display L-N and L-E voltages.
50 to 280Vac (sine).
- Display line path impedance.
0.01-2000Ω (software ctrl).
- Display earth path impedance.
0.01-2000Ω (software ctrl).
- Display neutral path impedance.
0.01-2000Ω (software ctrl).
- Display psc line to neutral.
6kA@230Vac supply.
- Display psc line to earth.
6kA@230Vac supply.
- Re-scroll trough previous results.
- Bat. ok / low battery indicator.
- Auto-off function.
- Color coded test leads.
- Rugged Case.
- Ultra low power consumption.
- IEC/EN 61010-1 CAT III 270V

SPECIFICATIONS

Loop / Earth / Wires	0.03-2000Ω(auto-ranging)
Prospective Short Circuit	0~6kA at 230Vac
Operating Voltage	50V ~ 275Vac (50Hz)
Best Performance at Rated Voltage	230Vac ±20% Max. 10A
Accuracy of Voltage	±1%(210~250V) ±3% otherwise
Accuracy of Loops / Earth	±2%(0.05~50W)
Accuracy of Wires Impedances	±15%(above 500W)
Operating-Temperature	0°C~40°C
-Humidity	85% Maximum
Dimensions	205(L) x 90 (W) x 55(D)mm
Weight	Approx. 570g (battery included)
Power Source	1.5V SUM-3 (R6P)x6 or equivalent
Accessories	Test leads (AL-34) Heavy-duty case Instruction manual Batteries

The 2726NA is the first portable real electrical network analyzer. It has a built-in earth tester which does not requires the use of poles or long wires. This instrument is useful for fault- finding or commissioning of electrical installations. Differentiating between the line (hot), neutral and earth (ground) path by reading their values has never been easier. Bad contacts, old wiring or bad earth path are quickly identified. Faulty electrical network can be resolved in a fraction of the time normally required using conventional equipment. Down time due to a faulty electrical network is minimal as the fault can be identified and diagnosed quickly. Find which wire needs to be attended to and why (find those old wires with high impedance before a fire starts and replaces them). The complete electrical network can be analyzed by scrolling through the results. Of course, it has a built-in loop impedance and prospective short circuit tester as well as a voltmeter.

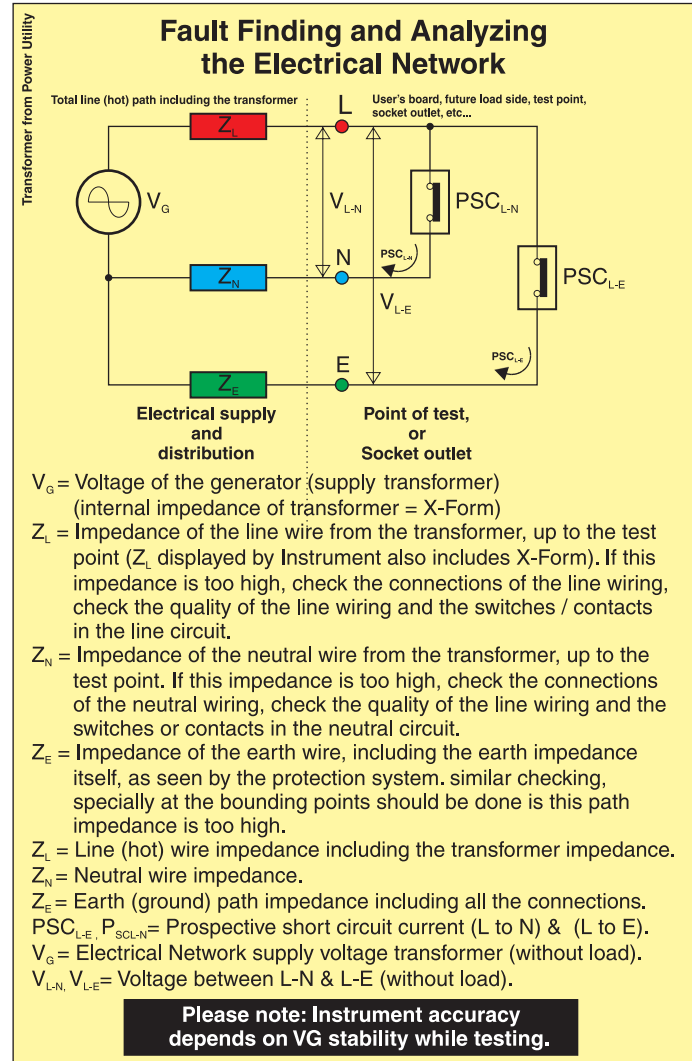

Test leads

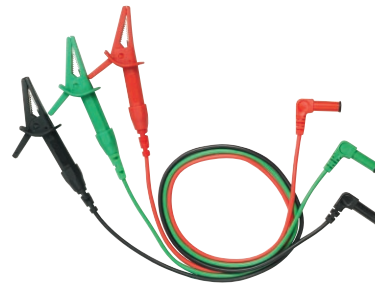

CE

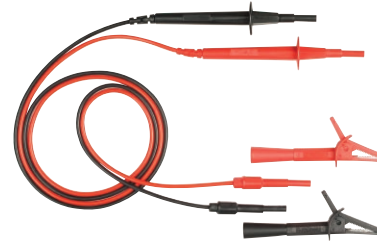
Test Leads

2801 IN

FEATURES

- Microprocessor controlled with advanced safety features.
- Three test voltages 250/500/1000V.
- Displays and sound warning if external voltage is present.
- Battery life extended by Enersave™ feature.
- Continuous battery monitoring.
- Auto-ranging/auto-null/auto-off.
- Insulation tested at 1 mA.
- Built-in carrying case, test leads in separate pouch.
- Real-time bargraph display of test voltage and voltage decay during discharge.
- Audible and visual message displayed if external voltage is present.
- Large LCD.
- Display can be customized for special orders.
- Continuity buzzer.
- Show test time duration (up to 99.9s) for easy comparison.
- IEC/EN 61010-1 CAT III
- BS 16th edition.

Test Leads Connections



SPECIFICATIONS

Insulation Resistance

Insulation Voltage(DC V)	250V	500V	1000V
Insulation Resistance (Auto-Ranging)	0-1000MΩ	0-2000MΩ	0-3000MΩ
Output Current	1mA DC min at 0.25MΩ (250V) 1mA DC min at 0.5MΩ (500V) 1mA DC min at 1MΩ (1000V)		
Accuracy	±3%rdg		

Continuity

Low-Resistance	0-500Ω
Resolution	0.001Ω
SC Current	220mA
Accuracy	±1.0%rdg

General

Dimensions	170(L) × 120(W) × 95(D)mm
Weight	Approx. 850g (battery included)
Power Source	1.5V(Type AA) × 8 Batteries
Accessories	Test leads (AL-30+AL-30C) Shoulder belt Instruction manual Batteries

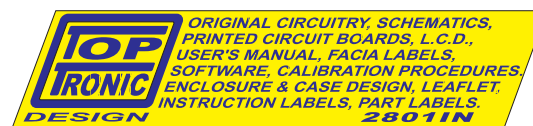



CE

2803 IN



CE

2804 IN
FEATURES

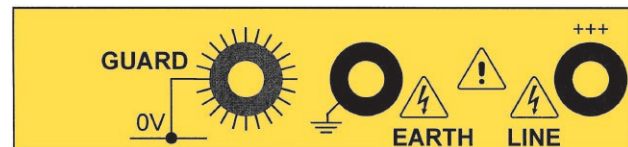
- Microprocessor controlled with advanced safety features.
- Displays and sound warning if external voltage is present.
- Battery life extended by Enersave™ feature.
- Continuous battery monitoring.
- Auto-ranging/auto-off.
- Built-in carrying case, test leads in separate pouch.
- Real-time bargraph display of test voltage and voltage decay during discharge.
- Audible and visual message displayed if external voltage is present.
- Large LCD.
- Display can be customized for special orders.
- Show test time duration (up to 99.9s) for easy comparison.
- EEPROM calibration.
- EN61010-1 IEC 1010-1 CAT III

Test Leads Connections

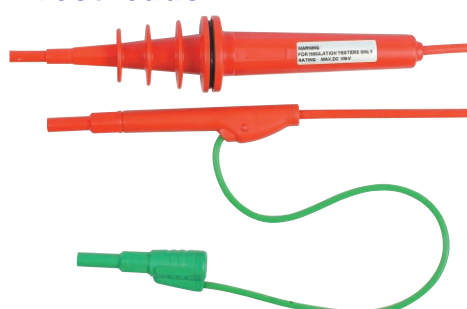
SPECIFICATIONS

Model	2803 IN				2804 IN			
Test Voltage (DC V)	0.5KV	1KV	2.5KV	5KV	1KV	2.5KV	5KV	10KV
Measuring Ranges (Auto-Ranges)	0-25GΩ	0-50GΩ	0-125GΩ	0-250GΩ	0-50GΩ	0-125GΩ	0-250GΩ	0-500GΩ
Accuracy	0-50GΩ : ±3% of reading 50-250GΩ : ±5% of reading				0-50GΩ : ±3% of reading 50-500GΩ : ±5% of reading			
Dimensions	170(L)×120(W)×95(D)mm				170(L)×120(W)×95(D)mm			
Weight (Battery Included)	930g Approx.				1030g Approx.			
Power Source	1.5V (AA)×8 Batteries				1.5V (AA)×8 Batteries			
Accessories	Test leads Shoulder belt Instruction manual Batteries				Test leads Shoulder belt Instruction manual Batteries			

Test leads

AL-50



AL-30



AL-30C

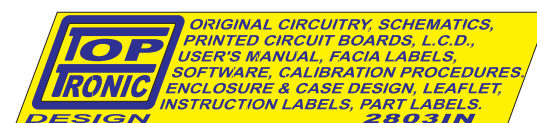



FEATURES

- Microprocessor controlled with advanced safety features.
- Displays and sound warning if external voltage present.
- Displays mains voltage, scroll trough menus.
- Checks wiring integrity (LEDs and display).
- Single button operation.
- Auto-off/auto-ranging.
- Microprocessor controlled.
- Combined prospective short circuit current, PSC and LOOP tester.
- Built-in carry case, test leads in separate pouch.
- Loop test for L-E and L-N and PSC.
- Voltage test L-N and L-E.
- Enables analysis of constituent components in L-E and L-N loops giving resistance of earth, neutral wire, live wire and transformer winding.
- Display can be customized for special orders.
- 60 Hz available on request.
- IEC/EN 61010-1 CAT II 250V

2811 LP

SPECIFICATIONS

Loop Impedance Range L-E,L-N	20/200/2000Ω (Auto-Range)
Loop Impedance Test Current	12A at 230V/50Hz
Voltage Measurement L-N,L-E	80 to 250V AC/50Hz
Earth wire/path return resistance	20/200/2000Ω (Auto-Range)
Neutral Wire Return Resistance	20/200/2000Ω (Auto-Range)
Line Wire Return Resistance & Transformer Windings	20/200/2000Ω (Auto-Range)
PSC Current (L-N) Max	3kA
Operating Voltage	230V±20%/Hz
Typical Accuracy	
Loop Impedance	±5%rdg ± 2dgt
PSC Current	±20%rdg ± 5dgt
Voltage	±1%rdg ± 1dgt
Operating-Temperature	-10°C to + 40 °C
-Humidity	80% max relative humidity
Dimensions	170(L)×120(W)×95(D)mm
Weight	780g (battery included)
Power Source	1.5V(AA)×8 Batteries
Accessories	Test leads Shoulder belt Instruction manual Batteries

Fault Finding and Analyzing the Electrical Network

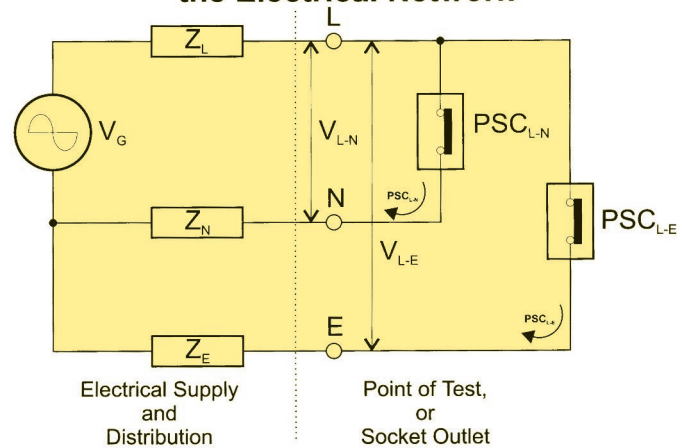

TEST LEADS

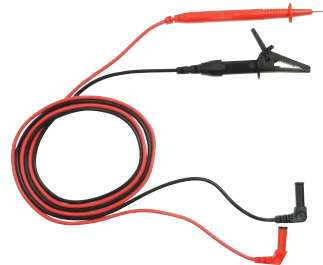

TEST LEADS

2820 EL
FEATURES

- Operating voltage 100-450V L-E.
- Rated current 999mA, at 317V AC/50Hz
- Checks ELCB trip time and trip point (sensitivity).
- Auto-Off/Auto-Ranging.
- Phase angle selection (0° / 180°).
- Indicates tripping phase angle.
- Impact resistant enclosure.
- Over temperature shut-down.
- Transient protection.
- Suitable for heavy industrial use.
- Fused.
- EN61010-1 IEC 1010-1 CAT III 450V

OPERATING PRINCIPLES
EARTH LEAKAGE TESTS

The testers may be used to check the trip point (Test 1) of the ELCB or the trip time (Test 2).

Test 1 is normally used on instantaneous ELCB s while Test 2 is normally used on inverse and fixed time-delay ELCBs.

TEST PROCEDURE

Test 1- instantaneous ELCBs A ramp current, increasing at approximately 12 mA/s is introduced between L and E and the point at which the ELCB trips is recorded. To save time and reduce energy dissipation, the starting point of the ramp may be selected. Test 2- Inverse and fixed time delay ELCBs. A constant current is selected and injected between L-E and the tripping time is recorded.

SPECIFICATIONS

Trip Current-Range	0-1 A at 317V (Auto-Range Programmable)
Trip Current-Resolution	1mA
Operating Voltage (L-E)	100-450V
Phase Angle Setting	0° and 180° selectable
Timer-Max	99.999S
Timer-Resolution	1ms
Typical Accuracy	
Trip-Current	±1%rdg ±1mA
Trip-Time	±1%rdg ±1dgt
Voltage	±3%rdg ±1dgt
Operating-Temperature	-10°C to + 40 °C
-Humidity	80% Max relative humidity
Dimensions	170(L) ×120(W) ×95(D)mm
Weight (Battery Included)	800g
Power Source	1.5V(AA) ×8 Batteries
Accessories	Test leads Shoulder belt Instruction manual Batteries

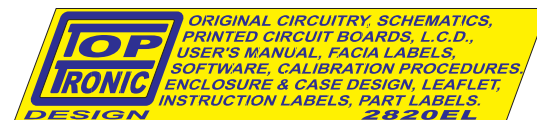



CE

4101 IN

CE

4102 MF

- This Family (4101 IN and 4102 MF) of Originally Designed Unique Products have features ranging from Insulation Resistance Testing, Voltage (ac-dc) measurements with Automatic Hold facility, Continuity Test with a short circuit current of minimum 200mA.
- Two very unique features are found on the Multifunction Model 4102MF; MOV and Gas Arrester Testing.
- Today, most equipments and electrical installations are protected by MOVs and Gas arresters.
- The 4102MF can test these devices to establish if the devices are still operating correctly or not.
- Energy conservation is featured on all these new Advanced Products.
- EnerSave™ limits the test duration to about 10 Seconds to save energy.
- This new generation of test equipments have no moving parts. All calibration are saved internally in a non volatile memory.
- Calibration can be done at any calibration facility around the world, without the need for dedicated calibration equipment.
- This makes these products easier to maintain and lower the cost of calibration and ownership.
- Their calibration interval can be extended without much problem.
- They comply to all the latest regulations, including UK.
- This product family is part of our new World Class series.
- Meets IEC/EN 61010-1 CAT III 600V

FEATURES COMPARISON

	4101IN	4102MF
Digital EE Calibration (No Potentiometers)	■	■
Keypad Operation	■	■
Automatic Voltmeter AC/DC at Start / Reset	■	■
ON-Reset/Restart Key	■	■
Off Push Button (press more than 5 Sec on 1kV key)	■	■
Auto-Off	■	■
MOV / Protection Devices Test	■	■
Test ON-OFF	■	■
Polarization Index (PI) on 250, 500 and 1000V	■	■
Dielectric Absorption Ratio (DAR) on 250, 500 and 1000V	■	■
Battery Test	Test Battery at Start	Test Battery at Start
Battery Test at Switch ON / Reset	■	■
Voltmeter on request by Keypad	Automatic	Automatic
Safety Voltmeter before each Test	■	■
Auto-Discharge on all Test and all Ranges	■	■
Continuity Short Circuit Current >220mA (225mA Typical)	■	■
Continuity Open Circuit Voltage of 5V dc	■	■
Nominal Voltage @ 1mA on all Insulation Ranges	■	■
Buzzer ON/OFF	Always ON	Always ON
Leads Auto-Null key	■	■
Test Auto-Stop	■	■
Display Customization for OEM	■	■
Re-programmable Microprocessor for Easy Updates	■	■
Can be calibrated in ALL calibration laboratories	■	■
Insulation measurement from 2kΩ (250V range) to 8GΩ (1kV Range)	■	■
Continuity from 0.01Ω (220mA) to 1999Ω	■	■
DC Voltmeter from ±1Vdc to ±950Vdc	■	■
AC Voltmeter from 1Vac to 700Vac	■	■
Accept 8 Rechargeable Batteries or Alkaline or Normal	■	■
Smart Hold & Stop on Voltmeter ac / dc	■	■
Gas Arrester Function	■	■
EnerSave™	■	■



STANDARD DIGITAL MULTIFUNCTION AND INSULATION CONTINUITY-VOLTAGE TESTER

SPECIFICATIONS

Insulation Test

	4101 IN	4102 IN
Test Voltage (DC V)	250V/500V/1000V	250V/500V/1000V
Output Voltage @ 1mA	Reted test Voltage +10% Max	
Measuring Ranges	2K-2G/4K-4G/8K-8G Ω	2K-2G/4K-4G/8K-8G Ω
Accuracy	<30kΩ:±20%rdg 30kΩ-1MΩ:±5%rdg >1MΩ:±3%rdg	<30kΩ:±20%rdg 30kΩ-1MΩ:±5%rdg >1MΩ:±3%rdg
When Voltage is constant, Current is Limited at	±1.2mA	±1.2mA
Short Circuit Current	±4mA Max	±4mA Max

Continuity Test

Measuring Ranges	0.01-1999Ω	0.01-1999Ω
Accuracy	0.01-100Ω : ±1.0% rdg 100-300Ω : ±1.5% rdg 300-1999Ω : ±2.0% rdg	0.01-100Ω : ±1.0% rdg 100-300Ω : ±1.5% rdg 300-1999Ω : ±2.0% rdg
Short Circuit Current	> 220mA	>220mA
Open Circuit Voltage	5V dc	5Vdc
Resolution	±2 counts	±2counts

Voltmeter

AC Voltage(Auto)	0-700V	0-700V
DC Voltage(Auto)	0-950V	0-950V
Accuracy	±1.5% of F.S.	±1.5% of F.S.
Resolution	±1V	±1V

MOV Test

Test Voltage	—————	5-1020Vdc
Voltage Result Accuracy	—————	±3%
Voltage Result Resolution	—————	±2 counts

GAS Arrester Test

Test Voltage	—————	5-1020Vdc
Voltage Result Accuracy	—————	±3%
Voltage Result Resolution	—————	±2 counts

Protections

Over Load	700V (between all terminals)
Over Voltage	Class III-700V towards ground
Fuses	1 X 500mA, 5 x 20mm, HBC, 600 Fast Blow

General

Display	2 lines x 16 characters LCD
Auto-Null Threshold	5Ω
Buzzer Threshold	3Ω
Fast Test	10Sec
Long Test	60Sec
With PI and DAR test Function	10Min
Load Battery Test Current	About 300mA
Power Source	1.5 x 8 (Type alkaline)
Dimensions	250(L) x 190(W) x 110(H)mm
Weight	1460g Approx. (battery included)
Operating Temperature	1°C to 55°C not in full sun
Storage Temperature	-20°C to 70°C
Accessories	Test leads (TEL-AL11-A) Shoulder belt Instruction manual Batteries

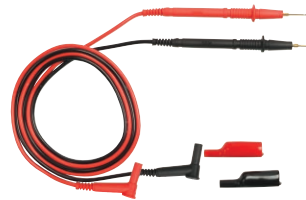

Test leads

4132 IN

FEATURES

- High quality Taut Band movement.
- Three insulation test voltages :
 - 1- 250Vdc -100MΩ
 - 2- 500Vdc -200MΩ
 - 3- 1000Vdc -400MΩ
- Two continuity test on "Low Ohms" :
 - 1- 500Ω
 - 2- 3Ω
- Small and lightweight, all in one case (do not need bag).
- AC voltmeter with linear scale up to 600 Vac.
- 200mA continuity short circuit current.
- 1mA test current on insulation test at nominal voltage.
- Automatic discharge of capacitance and inductive circuit with charge stored in the circuit under test.
- Live warning and display of external voltage presence.
- Fuse, air gap, crowbar and overload protected.
- On line battery monitoring shows if battery is ok.
- Very low battery consumption.
- On-Load battery check (+/205mA load for worst case).
- Operates on 8 dry batteries AA, R6P type.
- Mirror scale.
- Push and turn locking switch for long and hand free testing.
- Designed to meet international standards.
- Supplied with High Quality test leads.
- Designed to meet IEC 1010-1 CAT III 600V safety standard.
- BS 16th edition.

SPECIFICATIONS

Insulation Resistance

Test Voltage (DC V)	250V	500V	1000V
Output Ranges on open circuit	Rated test Voltage +10%		
Mirror Scale	100MΩ	200MΩ	400MΩ
Scale Multiplier	X 1/2	X 1	X 2
Mid-Scale	1MΩ	2MΩ	4MΩ
Accuracy	±5%		
Output Short-Circuit Current	±1.3mA		

Continuity

Low Ω	0-3Ω / 0-500Ω
Output Short-Circuit Current	≥210mA
Accuracy	±1.0% of scale length
Test leads / Fuse Zero Ω Adjustment by knob	

AC Voltage

AC Voltage Range	0-600VAC
Accuracy	±3% of scale length

General

Voltage Warning	Warning light circuit live lit from 90Vdc / 70Vac. Buzzer beep from 24Vac / dc.
Battery Check	Battery check indicate good batteries from 8Vdc to 13Vdc during a load test of 205mA
Battery OK	Battery OK Led lit from 6.5Vdc and is operative while testing
Power Source	1.5V (SUM-3) x 8. Type AA
Dimension	250(L) x 190(W) x 110(D)mm
Weight	Approx.1485g(battery included)
Accessories	Test leads (AL-24A) Fuse 0.5A 250V Shoulder belt Instruction manual Batteries



CE

4103 IN



CE

4104 IN
FEATURES

- 2 Lines x 16 Characters large LCD.
- Smart microprocessor controlled.
- Four insulation test voltages.
- Insulation resistance auto-ranging on all ranges.
- Measures insulation time test.
- Bar-graph indicates test voltage-rise and decay can be observed during tests.
- Warning and display of external voltage presence.
- ENER-SAVE™.
- Very low battery consumption.
- Low battery indicator.
- Over load protection.
- Auto-off.
- EN/IEC 61010-1 CAT III

SPECIFICATIONS

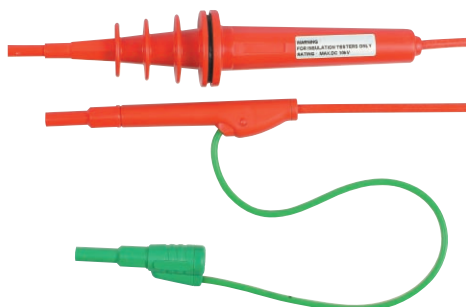
Model	4103 IN				4104 IN			
Test Voltage (DC V)	0.5KV	1KV	2.5KV	5KV	1KV	2.5KV	5KV	10KV
Measuring Ranges (Auto-Ranges)	0-30GΩ	0-60GΩ	0-150GΩ	0-300GΩ	0-60GΩ	0-150GΩ	0-300GΩ	0-600GΩ
Accuracy	±5% rdg				±5% rdg			
Output Power Limit	1W				1W			
Sealed with Gasket	V				V			
Insulation Resistance between Electrical Circuit and Housing : 2000MΩ/ 200V	V				V			
Withstand Voltage : 700 Vac for One Min. between Electrical Circuit and Case	V				V			
Operation-Temperature	-15°C to 55°C				-15°C to 55°C			
Operation-Humidity	80% Max. relative humidity				80% Max. relative humidity			
Weight	1670g Approx.				1900g Approx.			
Dimensions	250 (L) x 190(W) x 110(D)mm							
Power Source	1.5V (AA) x 8 Batteries							
Accessories	Test leads Instruction manual Shoulder belt Batteries							

Test leads

AL-50



AL-30



AL-30C

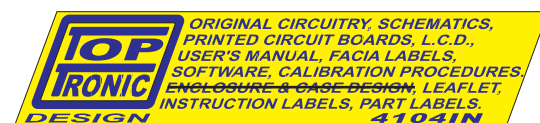

CE
4120 ER
FEATURES

- Capable of measuring earth voltage.
- 2mA measuring current permits the testing of earth resistance without tripping earth leakage current breakers in the circuit under test.
- In addition to facilitating for precision measurement, test leads for simplified two-wire measuring system also are supplied as standard accessories.
- Data hold function.
- Battery operated.
- Battery life indicator.
- EN/IEC 1010-1 CAT III 300V
- **Calibration performed with supplied test leads.**

SPECIFICATIONS

Measuring Ranges	Earth resistance 0-19.99/0-199.9/0-1999Ω Earth voltage 0-199.9 Vac (50-60Hz)
Accuracy	Earth Resistance ±(2%rdg+2dgts) at 200/2000Ω ±(2%rdg+0.1Ω) at 20Ω Earth Voltage ±(1%rdg+2dgts)
Earth Resistance Resolution	0-19.99Ω(0.01Ω) 0-199.9Ω(0.1Ω) 0-1999Ω(1Ω)
Measuring System	Earth resistance by constant current inverter 820Hz, 2mA approx.
Low Battery Indication	"" Symbol appears on the display
Data Hold Indication	"" Symbol appears on the display
Over Range Indication	"1" (MSD)
Open Circuit Indication	LED will be unlit
Display	LCD 3½ digit (2000 counts)
Dimensions	250(L) x 190(W) x 110(D)mm
Weight	Approx. 1500g (battery included)
Power Source	1.5V SUM-3 (R6P) x 8 Batteries or Equivalent
Accessories	Instruction manual. Test leads (AL-36 : red-15m, yellow-10m, green-5m+AL-33) Auxiliary earth spikes. Simplified measurement probe. Shoulder belt. Batteries.

CE
4105 ER
FEATURES

- Capable of measuring earth voltage.
- 2mA measuring current permits the testing of earth resistance without tripping earth leakage current breakers in the circuit under test.
- Battery life indicator.
- In addition to facilitating for precision measurement, test leads for simplified two-wire measuring system also are supplied as standard accessories.
- Battery operated.
- Lamp for the scale's panel. (auto shut-off in 10 seconds).
- EN/IEC 1010-1 CAT III 300V

SPECIFICATIONS

Measuring Ranges	Earth resistance 0-12 / 0-120 / 0-1200Ω Earth voltage 0-30 Vac(40~500Hz)
Accuracy	Earth resistance ±(2.5%+1mm) Earth voltage ±(2.5%+1mm)
Measuring System	Earth resistance by constant current inverter 820Hz, 2mA approx.
Open Circuit Indication	LED unlit
Dimensions	250(L) x 190 (W) x 110(D)mm
Weight	Approx. 1500g (battery included)
Power Source	1.5V SUM-3 (R6P) x 8 Batteries or Equivalent
Accessories	Instruction manual Test leads (AL-36 : red-15m, yellow-10m, green-5m+AL-33) Auxiliary earth spikes Simplified measurement probe Shoulder belt Batteries

Test leads



Development in progress

4134 ER

FEATURES

- Measures earth resistance.
- Three or four-terminal testing.
- Earth testing at 20, 200 and 2000Ω.
- Measures earth continuity.
- Determines soil resistivity.
- Essential when testing large earthing system where very low resistance is required.
- Large LCD.
- Potential lead resistance, current lead resistance and noise checks.
- "Full-Featured" EnerSave™ inside.
- EnerSave™ AUTO-HOLD.
- EnerSave™ AUTO-OFF.
- High noise rejection.
- Indicators show if reading may be invalid (R_p , R_c , and noise).
- High tolerance to spike resistance helps testing in urban areas.
- **Calibration performed with supplied test leads.**



AL-4WER

SPECIFICATIONS

Earth Resistance Ranges/Resolutions	0-20Ω / 0.01Ω 0-200Ω / 0.1Ω 0-2000Ω / 1Ω
Accuracy	±2%±2dgt
Test Current (A.C.RMS nominal)	20Ω / 10mA 200Ω / 1mA 2000Ω / 100uA
Test Frequency	128Hz ±1%
Interference(Which will not affect for more than±0.5% of reading)	5V(50/60Hz)
Maximum Current Spike Resistance (R_c)	20Ω / 2kΩ 200Ω / 5kΩ 2000Ω / 50kΩ
Maximum Current Spike Resistance (R_p)	20Ω / 2kΩ 200Ω / 5kΩ 2000Ω / 50kΩ
Maximum Output Voltage (C1-C2)	30Vrms
Voltage (AC-sine)	200V
Accuracy of Voltage	±1%±2dgt
Battery Low Indication Point	<8Vdc
Display	LCD 3½ digit (2000 counts)
Dimensions	250(L) x 190(W) x 110(D)mm
Weight	Approx. 1500g (battery included)
Power Source	1.5V SUM-3 (R6P) x 8 Batteries or Equivalent
Accessories	Test leads Instruction manual. Shoulder belt. Batteries.

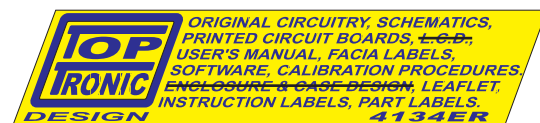



STANDARD

DIGITAL RCD TESTER



CE

Test leads

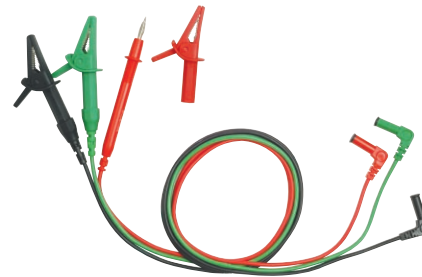

4112 EL

FEATURES

- 2 Lines x 16 Characters L.C.D.
- Very low consumption.
- Microprocessor controlled.
- Menu driven.
- Accurate digital readout of disconnection time.
- Automatic data hold function.
- Zero crossing circuitry permit testing at 0° or 180°.
- Disconnection phase polarity shown on L.C.D.
- Auto-Off and off override.
- Polarity trip indicator (positive or negative phase).
- Wiring polarity indicator.
- Measures voltage between Line and Earth before testing.
- IEC/EN 61010-1 CAT III 300V
- Indicates frequency of voltage L-E.

CONNECTIONS

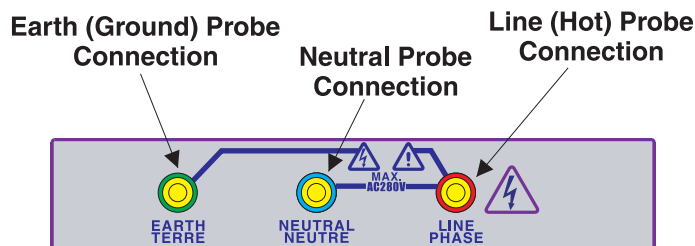

apply only Voltage Model @ 50Hz or 60 Hz.

Voltage Model (Vac) A=240, B=230, C=220, D=110

SPECIFICATIONS

Current Settings	3mA, 5mA, 7mA, 10mA, 15mA, 20mA, 30mA, 35mA, 50mA, 100mA, 125mA, 150mA, 175mA, 250mA, 300mA, 375mA, 500mA.
Current Selection	Rotary switch
Phase Start Selection	Referenced to Earth
0° and 180°	Yes
Over-Temperature Protection	Yes
Wiring Correctness Indication	Yes
Trip Indicator	Yes
Phase Polarity Trip Indicator	Yes
Operating Voltage (L-E)	Referenced to Earth 240Vac - 50Hz or 60 Hz Voltage Model (Vac)
Timer Resolution	1mS (max time=19.99S)
Timer Accuracy	1mS ±1mS
Current Accuracy	% proportional to voltage
Operating Temperature	- 5°C to 45°C
Storage Temperature	- 10°C to 85°C
Dimensions	250(L) x 190(W) x 110(D)mm
Weight	Approx. 1500g (battery included)
Power Source	1.5V(AA) x 8 Batteries Bat OK Led = Vbat > 7.5V
Accessories	Test leads Instruction manual Shoulder belt Batteries

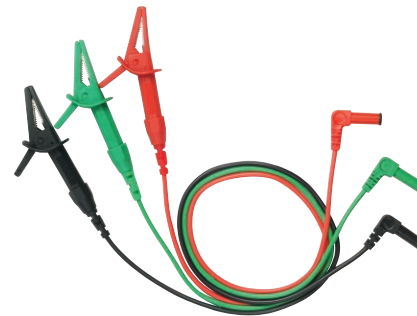

CE
Test leads

4126 NA

FEATURES

- 2 Lines x 16 Characters L.C.D.
- Auto-ranging / Auto-off.
- One push button operation.
- Very low consumption.
- Microprocessor controlled.
- Better than 3% accuracy (0.05-50 Ω).
- IEC/EN 61010-1 CAT III 300V

- Wiring integrity check (display + LEDs).
- Over temperature protection and indication.
- Stores previous readings.
- Measures : L-E and L-N AC voltages.
L-E and L-N Loop Impedance.
Prospective Short Circuits L-E and L-N.
Earth Spike, Line and Neutral Impedances.

SPECIFICATIONS

Loops / Earth / Wires	0.03-2000 Ω Auto-ranging
Prospective Short Circuit	0-6KA @ 230Vac
Operating Voltage	50-275Vac (50 Hz)
Best Performance at Rated Voltage	230Vac \pm 20% Max.10A
Operating Temperature	0 $^{\circ}$ C ~ 40 $^{\circ}$ C
Operating Humidity	20 $^{\circ}$ C ~ 60 $^{\circ}$ C
Storage Temperature	85% Maximum
Storage Humidity	85% Maximum
Accuracy of Voltages	\pm 1% (210~250V) \pm 3% otherwise
Accuracy Loops / Earth And Wires Impedances	\pm 2% (0.05~50 Ω) \pm 3%500 Ω \pm 15% (above 500 Ω)
Dimensions	250(L) x 190(W) x 110(D)mm
Weight	Approx.1500g (battery included)
Power Source	1.5V(AA) x 8 Batteries
Accessories	Test leads (AL-34) Instruction manual Shoulder belt Batteries



Fault Finding and Analyzing the Electrical Network

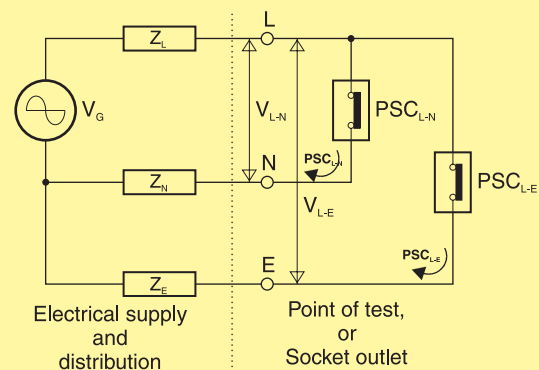

- V_G = Voltage of the generator (supply transformer) (internal impedance of transformer = X-Form)
- Z_L = Impedance of the line wire from the transformer, up to the test point (Z_L displayed by Instrument also includes X-Form). If this impedance is too high, check the connections of the line wiring, check the quality of the line wiring and the switches / contacts in the line circuit.
- Z_N = Impedance of the neutral wire from the transformer, up to the test point. If this impedance is too high, check the connections of the neutral wiring, check the quality of the line wiring and the switches or contacts in the neutral circuit.
- Z_E = Impedance of the earth wire, including the earth impedance itself, as seen by the protection system. similar checking, specially at the bounding points should be done is this path impedance is too high.

CE

Power Source : 110VAC or 230VAC

FEATURES

- Four terminal measurement.
- Measures down to 100uΩ.
- 5 Ranges from 200.0mΩ to 2000Ω.
- Minimum resolution of 100uΩ.
- Three test current with over-temperature protection.
- Protection against inadvertent connection to over-voltage.
- Large LCD.
- Potential lead resistance, current lead resistance checks.
- "Full-Featured" EnerSave™ inside.
- EnerSave™ AUTO-HOLD.
- EnerSave™ AUTO-OFF.
- Lightweight, robust & compact.
- Indicators show if reading may be invalid (R_p , R_c , and temperature).
- "O-Ring" sealed case.
- Future optional rechargeable battery.
- IEC/EN 61010-1

4136mO

CE

Power Source : 12VDC

SPECIFICATIONS
4137mO

Measuring Ranges	0-200.0m ohms in steps of 100uohm 0-2000m ohms in steps of 1m ohm 0-20.00 ohms in steps of 10m ohm 0-200.0 ohms in steps of 100m ohm 0-2000 ohms in steps of 1 ohm
Accuracy	±0.5% of reading ±2 digits over the operating temperature range, -15°C to +55°C, with the supplied test leads
Test Current	1mA =>2000 ohms range 10mA =>200/ 20 ohms ranges 100mA =>2000m / 200m ohm ranges
Test Current Accuracy	±0.1%
Protection Fuses	Mains = 0.5A, HBC, 5 x 20mm, DIN Current = 1A, HBC, 5 x 20mm, DIN Voltage = 0.5A, HBC, 5 x 20mm, DIN
Maximum Output Voltage (C1-C2)	20V
Dimensions	250(L) x 190(W) x 110(D)mm
Weight	4136mO:1530 g 4137mO:1500 g
Accessories	Test Leads(AL-34) Instruction manual Shoulder belt 1.5V(AA) x 8 Batteries(4137mO)

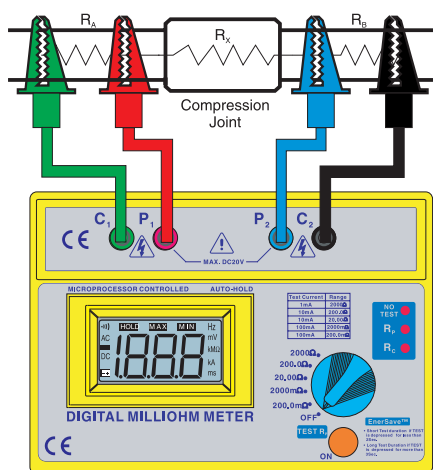
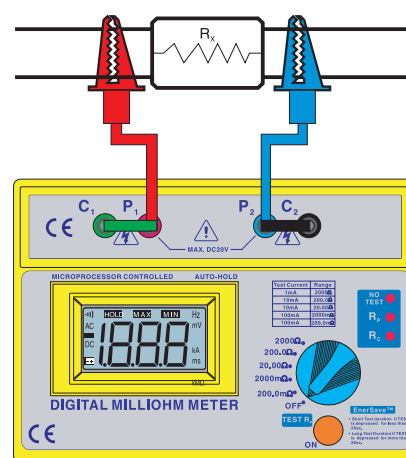
4 Terminals Test

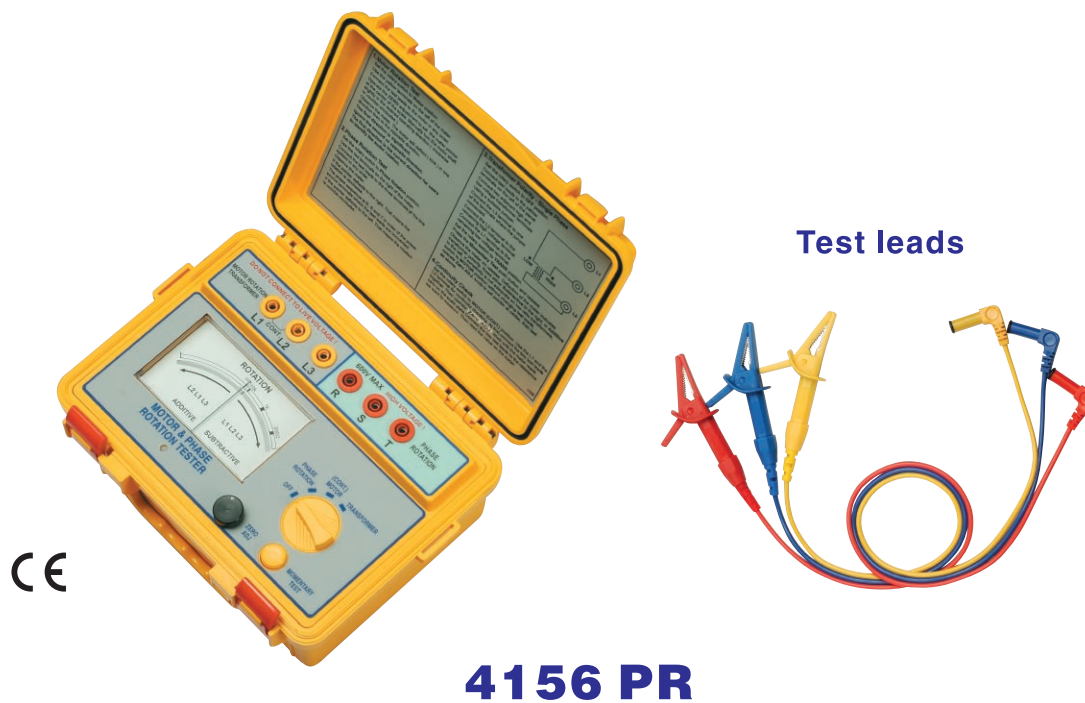
Simplified Measurement



4156 PR

APPLICATIONS

The **4156 PR** is used to identify the leads of a disconnected motor so that when the motor is in true phase sequence, it will run in the desired direction. The identification process is necessary before a motor can be connected. The tester is also used to identify true phase sequence of energized AC power lines up to 600 AC volts. The other functions of the **4156 PR** include the determination of transformer polarity and testing of circuit continuity.

OPERATION : The 4156 PR has three individual ranges for different applications.

1. In the PHASE ROTATION range, the meter is connected in the phase sequence circuit and the red terminals for phase rotation may be used to make a phase sequence measurement. The batteries are disconnected for the testing.
2. In the MOTOR range, the meter is disconnected from the phase sequence circuit and connected in the motor rotation circuit. The batteries are connected for the testing. The yellow terminals may now be used for a motor rotation test.
3. In the TRANSFORMER range, the meter and batteries are connected so that the yellow terminals can be used for a transformer polarity test. It is also designed for circuit continuity tests. Users can connect test leads to L1 and L2 terminals for continuity checking.

DESCRIPTION

The three red terminals on the right side (R, S, T) are used to connected to **energized ac** power systems up to **600 volts**. The other three yellow terminals on the left side (L1, L2, L3) are for connection to **de-energized** equipment. **Do not connect to Live Voltage !** The *Momentary Test* push-button is used to identify transformer polarity. Deflection of the rotation pointer indicates transformer polarity. Read either *Subtractive* on the right, or *Additive* to the left. The *Zero Adjustment knob* is used to check continuity.

Three 50cm-long test leads are supplied with the **4156 PR**. Each comes with a wide grip crocodile clip. The enclosure of the **4156 PR** is made with high impact ABS. The dimension of the tester is approx. 25 x 19 x 11 cm with the cover closed. The tester weight approximately 1.28 kg.

- **Safety Standard : IEC/EN 61010-1 CAT III 600V**

CE
4183 CP

The **4183 CP** is a Cable Phasing Meter that offers a quick method of measuring voltage and determining phase rotation of underground distribution systems using the capacitive test point of elbow connectors. Most manufacturers of high voltage cable terminations incorporate capacitive test points in their elbow connectors. These test points are designed for measuring purposes.

This instrument is battery powered and supplied with a ground and two measuring leads.

FEATURES

- Safe operates at low voltage.
- Measures system voltage.
- Measures capacitance of test point if system voltage is known.
- Checks phase rotation of cables.
- Phases out cables.
- Rugged - comes with portable case.
- Operates from potential test point of elbow connectors.
- Battery operated.
- Meets EN61000-3 EN61000-4
EN61326-1 EN55011

SPECIFICATIONS

Voltage Ranges	0~16kV / 0~32kV
Accuracy	±8% (exclusive of tap capacitance variations)
Tap Capacitance Setting	0.4 to 3.0 pF continuous per channel
Frequency	50 or 60 Hz
Dimensions	250(L) x 190(W) x 110(D)mm
Weight	Approx. 1420g (battery included)
Power Source	1.5V (AA) x 4 Batteries
Accessories	Test Leads Instruction manual Shoulder belt Batteries

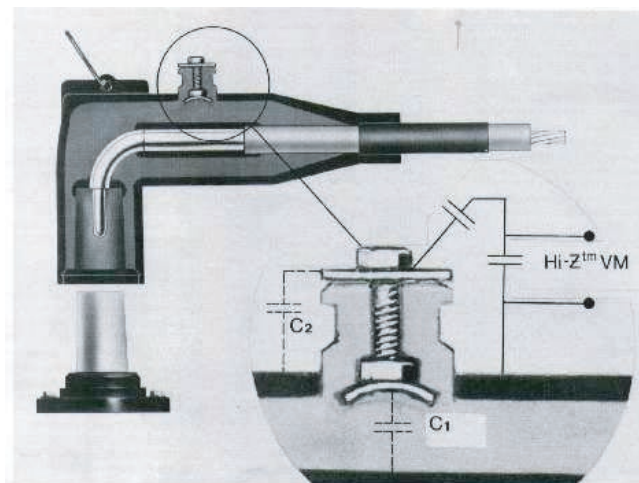

Test leads





CE
4167 MF

4167 MF multi- function tester is a combination of earth resistance tester and insulation tester. This two in one multi-function tester is an ideal tool for users to measure insulation and earth resistance.

FEATURES

- High quality Taut Band movement.
- Capable of measuring earth voltage.
- 2mA measuring current permits earth resistance tests with tripping earth leakage current breakers in the circuit under test.
- In addition to facilitating for precision measurement, test leads for simplified two-wire measuring system also are supplied as standard Accessories.
- Two insulation test voltage (DC) : 250V and 500V.
- Alternating voltage measurement.
- Battery life indicator.
- Battery operated.
- Fuse protected.
- Designed to meet EN 61010-1 safety standard.

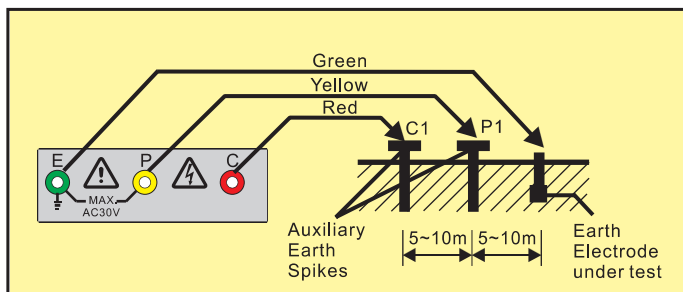
Earth Resistance Measurement



SPECIFICATIONS

EARTH RESISTANCE

Measuring system	Earth resistance by constant current inverter 820Hz, 2mA approx.
Measuring ranges	Earth resistance : 0-12/0-120/0-1200Ω Earth voltage : 0-30V AC 40-500Hz
Accuracy	Earth resistance : ±3%F.S. Earth voltage : ±2.5%F.S.

INSULATION

Test voltage (DC V)	250V	500V
Measuring ranges	0-100MΩ	0-200MΩ
Output voltage on open circuit	Rated test voltage +10%	
Short circuit terminal current	2mA DC	
Accuracy	±5% of scale length	

ACV

AC Voltage range	0-600V
Accuracy	±2.5% of full scale
Line frequency range	40-500Hz

- Dimensions :
250(L) x 190(W) X 110(D) mm
- Weight :
Approx. 1500g (battery included)
- Power source :
1.5V SUM-3 (R6P) x 8 pieces or equivalent
- Safety standard :
EN61010-1 CAT III 600V
- Accessories :
Test leads :
(1) AL-36 : red-15m, yellow-10m, green-5m
+AL-33 : simplified measurement probe.
(2) AL-24A : red- 90cm, black- 90cm.
Auxiliary earth spikes
Shoulder belt
Instruction manual
Batteries

Insulation Test Connections

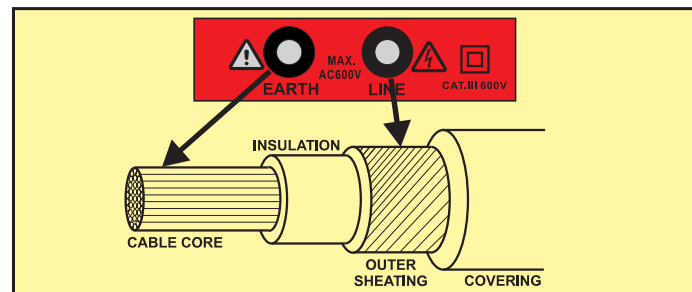



STANDARD

DIGITAL MULTIFUNCTION AND INSULATION CONTINUITY-VOLTAGE TESTER

Model: **4152 IN - 4160 MF**



CE

4153 IN



CE

4158 MF

- A new generation of Modern Digital MultiFunction Testers is born. These Testers have a range of new features not even found in Expensive Advanced Test Equipments.
- They are models 4152IN, 4153IN, 4154MF, 4155MF, 4156IN, 4157MF, 4158MF, 4159MF and 4160MF.
- All, not only Rugged, but designed to excel in Harsh environment, still, remaining low cost and affordable. They can be operated with rechargeable batteries, alkaline or low cost general purpose batteries.
- This Family of Originally Designed Unique Products have features ranging from Insulation Resistance Testing, Voltage (ac-dc) measurements with Automatic Hold facility, Diode Testing, Ohm Meter, Continuity Test with a short circuit current of minimum 220mA.
- Two very unique features are found on the Multifunction Models: MOV and Gas Testing.
- Today, most equipments and electrical installations are protected by MOVs and Gas arresters. Our new family of testers can test these devices to establish if the devices are still operating correctly or not.
- Energy conservation is featured on all these new Advanced Products. The Quick Test button run the test while its depressed, automatically stopping if the key is not pressed.
- EnerSave™ limit the test duration to about 10 Seconds.
- Quick Test and EnerSave™ are unique features. Both save energy.
- This new generation of test equipments have no moving parts. All calibration are saved internally in a non volatile memory. Calibration can be done at any calibration facility around the world, without the need for dedicated calibration equipment. This makes these products easier to maintain and lower the cost of calibration. Their calibration interval can be extended without much problem. They comply to all the latest regulations, including UK.
- This product family is part of our new World Class series.
- Meets IEC/EN 61010-1 CAT III 600V

FEATURES COMPARISON

Model	4152IN	4153IN	4154MF	4155MF	4156IN	4157MF	4158MF	4159MF	4160MF
Digital EE Calibration (No Potentiometers)	■	■	■	■	■	■	■	■	■
Keypad Operation	■	■	■	■	■	■	■	■	■
Automatic Voltmeter AC/DC at Start / Reset	■	■	■	■	■	■	■	■	■
ON-Reset/Restart Key	■	■	■	■	■	■	■	■	■
Off Push Button	■	■	■	■	■	■	■	■	■
Auto-Off	■	■	■	■	■	■	■	■	■
MOV / Protection Devices Test	■	■	■	■	■	■	■	■	■
Quick Test (Test While Press Quick Test)	EnerSave™	■	■	■	■	EnerSave™	EnerSave™	EnerSave™	EnerSave™
Test ON-OFF	■	■	■	■	■	■	■	■	■
Guard Terminal for Precision High Resistance Test	■	■	■	■	■	■	■	■	■
Polarization Index (PI) on 250, 500 and 1000V	■	■	■	■	■	■	■	■	■
Dielectric Absorption Ratio (DAR) on 250, 500 and 1000V	■	■	■	■	■	■	■	■	■
Battery Test by Key	Test Battery at Start	■	■	■	Test Battery at Start	Test Battery at Start	Test Battery at Start	Test Battery at Start	Test Battery at Start
Battery Test at Switch ON / Reset	■	■	■	■	■	■	■	■	■
Voltmeter on request by Keypad	Automatic	■	■	■	■	■	■	■	■
Safety Voltmeter before each Test	■	■	■	■	■	■	■	■	■
Auto-Discharge on all Test and all Ranges	■	■	■	■	■	■	■	■	■
Continuity Short Circuit Current >220mA (225mA Typical)	■	■	■	■	■	■	■	■	■
Continuity Open Circuit Voltage of 5V dc	■	■	■	■	■	■	■	■	■
Nominal Voltage @ 1mA on all Insulation Ranges	■	■	■	■	■	■	■	■	■
Buzzer ON/OFF by Key	Always ON	■	■	■	■	■	■	■	■
Leads Auto-Null key	■	■	■	■	■	■	■	■	■
Test Auto-Stop	■	■	■	■	■	■	■	■	■
Display Customization for OEM	■	■	■	■	■	■	■	■	■
Re-programmable Microprocessor for Easy Updates	■	■	■	■	■	■	■	■	■
Can be calibrated in ALL calibration laboratories	■	■	■	■	■	■	■	■	■
Insulation measurement from 2kΩ (250V range) to 8GΩ (1kV Range)	■	■	■	■	■	■	■	■	■
Continuity from 0.01Ω (220mA) to 1999Ω	■	■	■	■	■	■	■	■	■
DC Voltmeter from 1Vdc to 950Vdc	■	■	■	■	■	■	■	■	■
AC Voltmeter from 1Vac to 700Vac	■	■	■	■	■	■	■	■	■
Ohm Meter 400kΩ resistance range	■	■	■	■	■	■	■	■	■
Diode Test @ 1.1 to 1.2mA dc	■	■	■	■	■	■	■	■	■
Accept 8 Rechargeable Batteries or Alkaline or Normal	■	■	■	■	■	■	■	■	■
Smart Hold & Stop on Voltmeter ac / dc	■	■	■	■	■	■	■	■	■
Gas Arrester Function	■	■	■	■	■	■	■	■	■
EnerSave™	■	■	■	■	■	■	■	■	■



STANDARD DIGITAL MULTIFUNCTION AND INSULATION CONTINUITY-VOLTAGE TESTER

SPECIFICATIONS

Insulation Test	INSULATION TESTERS	MULTIFUNCTION TESTERS
Test Voltage (DC V)	250V/500V/1000V	250V/500V/1000V
Output Voltage @ 1mA	Reted test Voltage +10% Max	
Measuring Ranges	2K-2G/4K-4G/8K-8G Ω	2K-2G/4K-4G/8K-8G Ω
Accuracy	<30kΩ:±20%rdg 30kΩ-1MΩ:±5%rdg >1MΩ:±3%rdg	<30kΩ:±20%rdg 30kΩ-1MΩ:±5%rdg >1MΩ:±3%rdg
When Voltage is constant, Current is Limited at	±1.2mA	±1.2mA
Short Circuit Current	±4mA Max	±4mA Max

Continuity Test	INSULATION TESTERS	MULTIFUNCTION TESTERS
Measuring Ranges	0.01-1999Ω	0.01-1999Ω
Accuracy	0.01-100Ω : ±1.0% rdg 100-300Ω : ±1.5% rdg 300-1999Ω : ±2.0% rdg	0.01-100Ω : ±1.0% rdg 100-300Ω : ±1.5% rdg 300-1999Ω : ±2.0% rdg
Short Circuit Current	> 220mA	>220mA
Open Circuit Voltage	5V dc	5Vdc
Resolution	±2 counts	±2counts

Voltmeter	INSULATION TESTERS	MULTIFUNCTION TESTERS
AC Voltage(Auto)	0-700V	0-700V
DC Voltage(Auto)	0-950V	0-950V
Accuracy	±1.5% of F.S.	±1.5% of F.S.
Resolution	±1V	±1V

MOV Test	INSULATION TESTERS	MULTIFUNCTION TESTERS
Test Voltage	—————	5-1020Vdc
Voltage Result Accuracy	—————	±3%
Voltage Result Resolution	—————	±2 counts

GAS Arrester Test	INSULATION TESTERS	MULTIFUNCTION TESTERS
Test Voltage	—————	5-1020Vdc
Voltage Result Accuracy	—————	±3%
Voltage Result Resolution	—————	±2 counts

Diode Test	INSULATION TESTERS	MULTIFUNCTION TESTERS
Test Voltage	—————	5 Vdc
Max Test Current	—————	1.5mA
Resolution	—————	0.1V
Measurement Voltage	—————	0-4.5V
Accuracy	—————	3%
Resolution	—————	±2 counts

Protections	INSULATION TESTERS	MULTIFUNCTION TESTERS
Over Load	700V (between all terminals)	
Over Voltage	Class III-700V towards ground	
Fuses	1 X 500mA, 5 x 20mm, HBC, 600 Fast Blow	

General	INSULATION TESTERS	MULTIFUNCTION TESTERS
Display	2 lines x 16 characters LCD	
Auto-Null Threshold	5Ω	
Buzzer Threshold	3Ω	
Fast Test	10Sec	
Long Test	60Sec	
With PI and DAR test Function	10Min	
Load Battery Test Corrent	About 300mA	
Power Source	1.5 x 8 (Type alkaline)	
Dimensions	250(L) x 190(W) x 110(H)mm	
Weight	1460g Approx. (battery included)	
Operating Temperature	1 °C to 55 °C not in full sun	
Storage Temperature	-20 °C to 70 °C	
Accessories	Test leads (TEL-AL11-A) Instruction manual	Shoulder belt Batteries

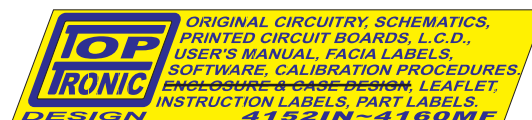

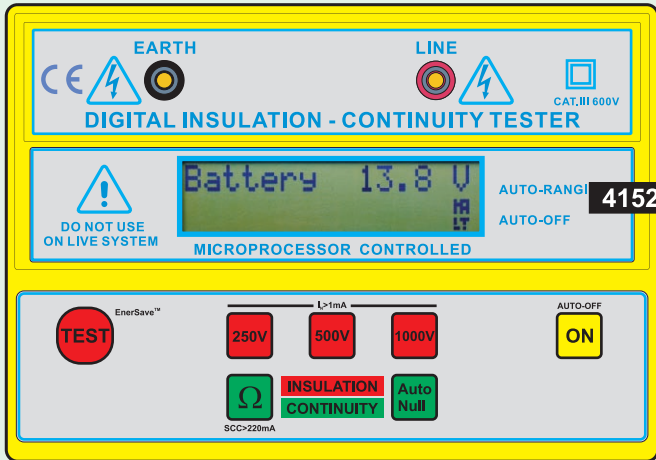

4152IN showing the Battery test during start up.

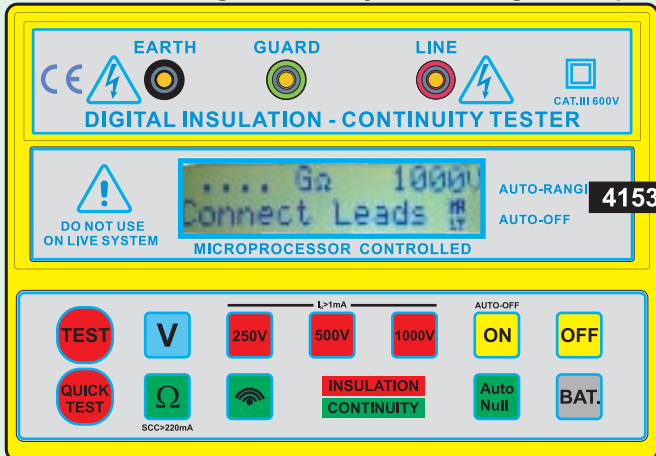

4153IN interactive display asking to connect leads.

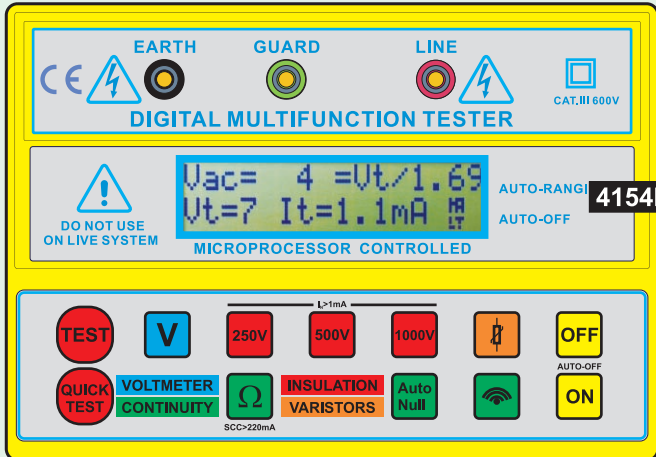

4154MF display of MOV test results.

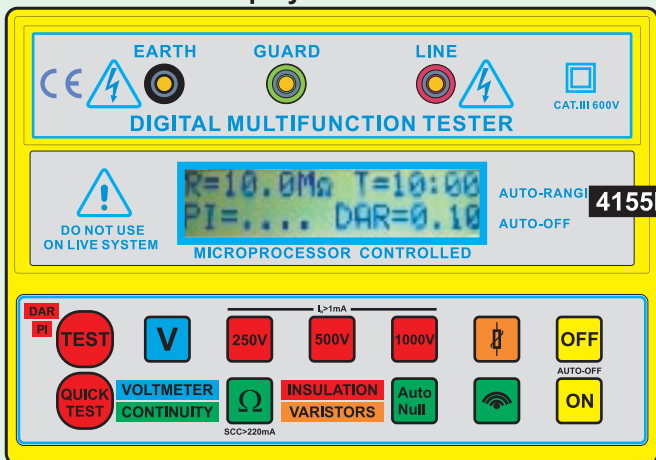

4155MF display of PI and DAR test results.

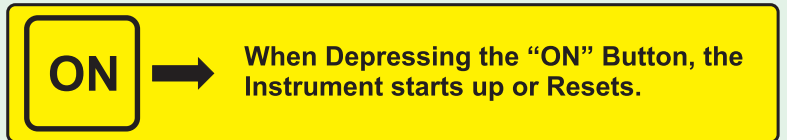

When Depressing the “ON” Button, the Instrument starts up or Resets.

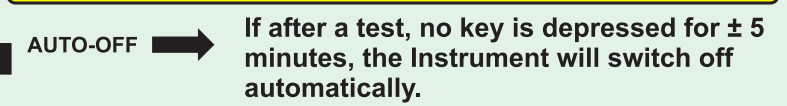

If after a test, no key is depressed for ± 5 minutes, the Instrument will switch off automatically.

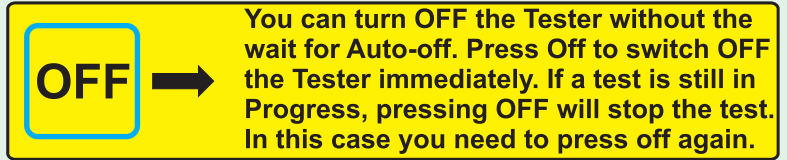

You can turn OFF the Tester without the wait for Auto-off. Press Off to switch OFF the Tester immediately. If a test is still in Progress, pressing OFF will stop the test. In this case you need to press off again.

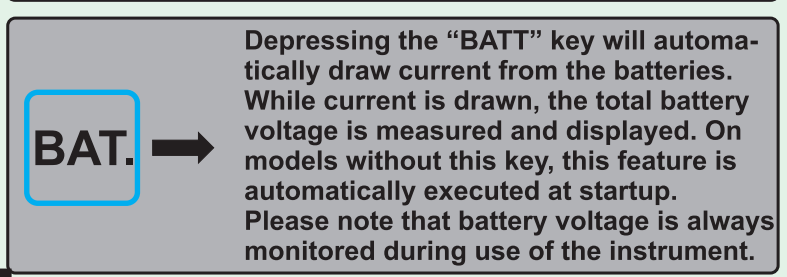

Depressing the “BATT” key will automatically draw current from the batteries. While current is drawn, the total battery voltage is measured and displayed. On models without this key, this feature is automatically executed at startup. Please note that battery voltage is always monitored during use of the instrument.

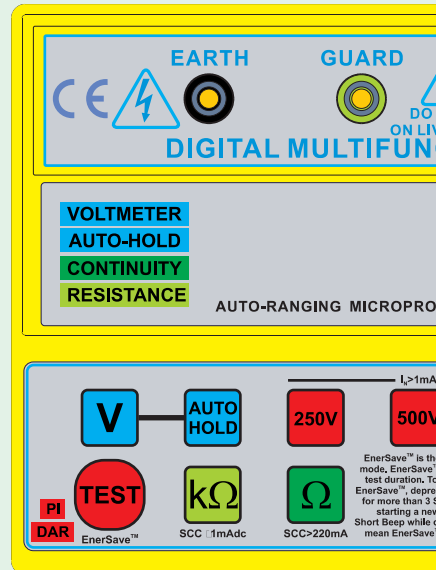
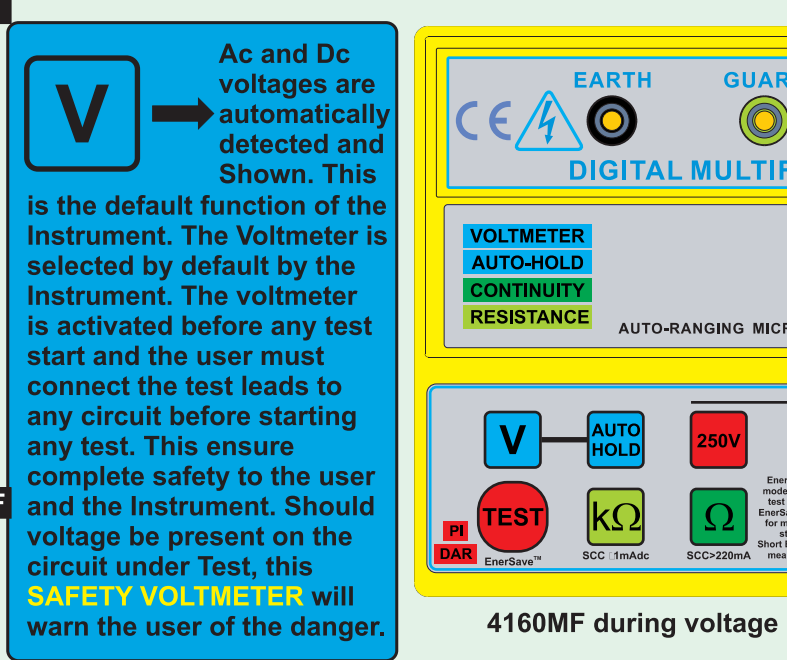

4160MF during voltage mea

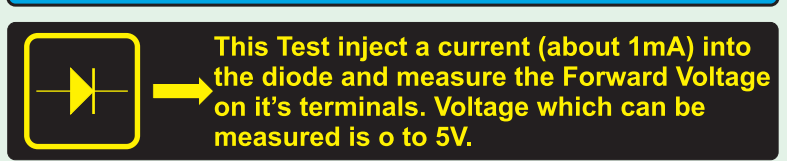
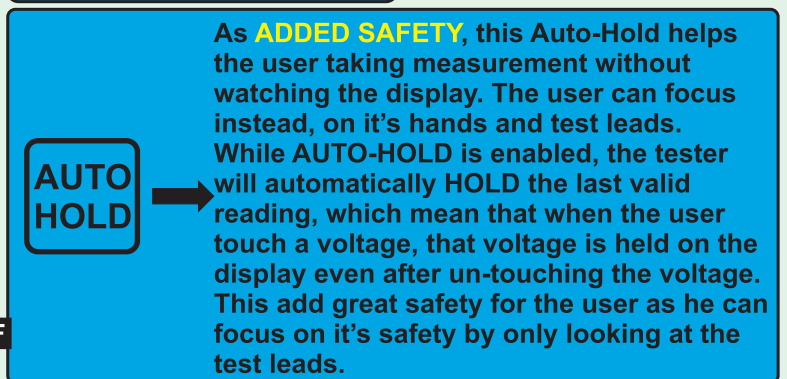

All Functions are using an eas

250V 500V 1000V → Insulation test Voltage selection is done by Depressing the corresponding key.

TEST → Depress to Start or Stop the Selected Test

EnerSave™ → EnerSave™ is a Smart Program which Save Energy when ever possible by limiting the Test Duration.

QUICK TEST → Test is performed while this key is depressed and stop when released. Models with this key do not have EnerSave™ because they don't need it.

DAR → This is the ratio of the Insulation Resistance at 1 Min divided per the Insulation Resistance at 30 Seconds.

PI → This is the ratio of the Insulation Resistance at 10 Min divided per the Insulation Resistance at 1 Minute.

4160MF

DO NOT USE ON LIVE SYSTEM
CAT. III 600V

GAS ARRESTER
INSULATION
VARISTORS
DIODES

SCC>220mA

L>1mA
500V 1000V
Tc: 1mAadc
Tc: 1mAadc

EnerSave™ is the default mode. EnerSave™ limit the test duration. To disable EnerSave™, depress "TEST" for more than 3 Sec while ringing a new test, beep while depressing "TEST" and EnerSave™ is OFF.

Auto Null
ON

MOV Test
This Key select the MOV Test. Today's new Equipments and Electrical Installations are generally Protected by MOVs. It is now easy to test these devices to ensure their proper working and replace them if found damaged. The knee Voltage is shown on the display.

Gaz Arrester Function
The Trigger Threshold Voltage is shown on the LCD. All Gaz protection can be Tested, including Neon Lights.

measurement with Auto-Hold

Ω → Select the Continuity test which has a Short Circuit Current of 220mA. Complies to all latest standard.

Auto Null → Auto-Null the resistance of the test leads and of the fuse so that continuity measurements can show only the resistance under test.

Buzzer → Turn Buzzer On or Off. When ON, low resistance value BEEP when low. It's helping when tracing circuitry.

kΩ → Select the Ohm Meter which has a Short Circuit Current of ±1mA. It can measure up to 400K Ohms.

4156IN

DO NOT USE ON LIVE SYSTEM
MICROPROCESSOR CONTROLLED

100.1 Ω
Continuity

AUTO-RANGING
AUTO-OFF

TEST V 250V 500V 1000V kΩ OFF
QUICK TEST CONTINUITY Ohm Meter Auto Null ON

4156IN showing the Continuity Test in Progress

4157MF

DO NOT USE ON LIVE SYSTEM
MICROPROCESSOR CONTROLLED

10.05 Ma 1000V
Hold

AUTO-RANGING
AUTO-OFF

TEST V 250V 500V 1000V OFF
CONTINUITY kΩ INSULATION VARISTORS Auto Null ON

4157MF InsulationTest stopped early by EnerSave™

4158MF

DO NOT USE ON LIVE SYSTEM
MICROPROCESSOR CONTROLLED

10.05 Ma 1000V
+ 12.00

AUTO-RANGING
AUTO-OFF

TEST V 250V 500V 1000V OFF
CONTINUITY kΩ INSULATION VARISTORS Auto Null ON

4158MF During InsulationTest Auto-Discharge

4159MF

DO NOT USE ON LIVE SYSTEM
MICROPROCESSOR CONTROLLED

Forward Voltage
Diode Vf=0.51V

AUTO-RANGING MICROPROCESSOR CONTROLLED

TEST V 250V 500V 1000V OFF
CONTINUITY kΩ INSULATION VARISTORS Auto Null ON

4159MF During diode test

easy "human minded" interface



STANDARD

ANALOG H.V. INSULATION TESTER



6200 IN



6201 IN

FEATURES

- Microprocessor controlled.
- High quality Taut Band movement.
- Two insulation test voltages.
- Insulation resistance, auto ranging on all ranges.
- Low Battery LED indication.
- Beeper warning of external voltage.
- Fully protected : crow bar.
- Housed in heavy-duty carry case.

SPECIFICATIONS

Model	6200 IN		6201 IN	
Test Voltage (DC V)	2500V	5000V	5000V	10000V
Measuring Ranges	0-100GΩ	0-200GΩ	0-200GΩ	0-400GΩ
Accuracy	±5% of full scale			
Live Warning	>500 Volts AC			
Operating-Temperature	0° C to 40° C			
Operating-Humidity	85% Max. relative humidity			
Weight	3500g (battery included)			
Dimensions	330(L) x 260(W) x 160(D)mm			
Power Source	1.5V "C" x 8 Alkaline Batteries			
Accessories	Test leads (AL-50+AL-30+AL-30C) Instruction manual Batteries			

Test leads

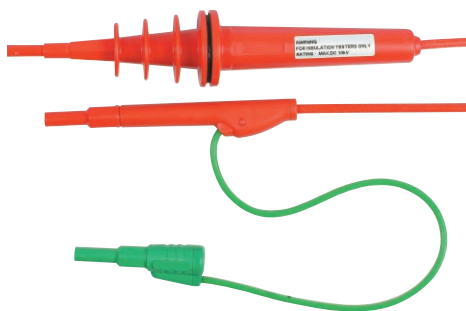

AL-50



AL-30



AL-30C

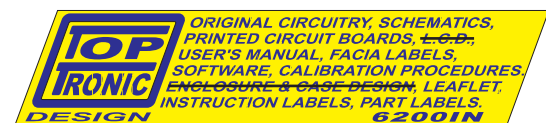



STANDARD

DIGITAL H.V. INSULATION TESTER



CE

6210A IN



CE

6211A IN

FEATURES

- Microprocessor technology ensures high performance accuracy and reliability.
- Four insulation test voltages (DC V).
- Insulation resistance, auto ranging on all ranges.
- Bargraph indicates test voltage, decay can be observed during discharge.
- Measures insulation test time.
- Display warning of external voltage.
- Fully protected : crow bar.
- Housed in heavy duty carry case.
- EEPROM calibration.
- EN/IEC 61010-1 CAT III

SPECIFICATIONS

Model	6210A IN				6211A IN			
Test Voltage (DC V)	0.5KV	1KV	2.5KV	5KV	1KV	2.5KV	5KV	10KV
Measuring Ranges (Auto-Ranges)	0-25GΩ	0-50GΩ	0-125GΩ	0-250GΩ	0-50GΩ	0-125GΩ	0-250GΩ	0-500GΩ
Accuracy	±3%rdg ±3dgt				±3%rdg ±3dgt			
Output Current Limit	50uA to 100uA (1W)				50uA to 100uA (1W)			
Live warning	> 500V AC				> 500V AC			
Operating-Temperature	0°C ~ 40°C				0°C ~ 40°C			
Operating-Humidity	85% Max. relative humidity				85% Max. relative humidity			
Weight	3.5kg Approx.				3.6kg Approx.			
Dimensions	330(L) x 260(W) x 160(D)mm				330(L) x 260(W) x 160(D)mm			
Power Source	1.5V "C" x 8 Alkaline Batteries				1.5V "C" x 8 Alkaline Batteries			
Accessories	Test leads (see page 47) Instruction manual Batteries				Test leads (see page 47) Instruction manual Batteries			

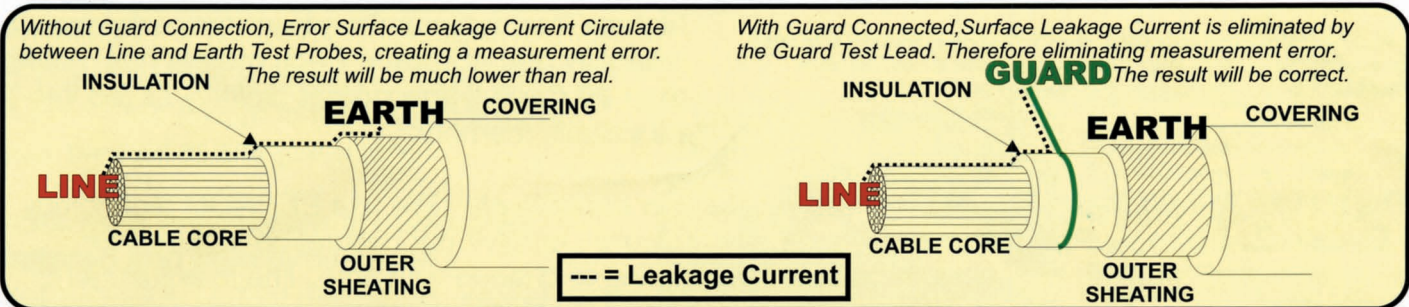



CE

6212A IN

FEATURES

- Microprocessor technology ensures high performance accuracy and reliability.
- Insulation test voltages (0.5kV-10kV).
- Insulation resistance, auto ranging on all ranges.
- Bargraph indicates test voltage, decay can be observed during discharge.
- Measures insulation test time.
- Display warning of external voltage.
- Fully protected : crow bar.
- Housed in heavy duty carry case.
- EEPROM calibration.
- Display test duration for easy comparison.
- EN/IEC 61010-1 CAT III

SPECIFICATIONS

Test Voltage(DC V)	0.5kV to 10kV (0.5kV increment steps)
Insulation Resistance (Auto-ranging)	25GΩ / 0.5kV 25GΩ at 0.5kV → 500GΩ at 10kV
Accuracy	±3%rdg ±1dgt
Output Current Limit	50uA to 100uA(1W)
Live Warning	> 500V AC
Operating-Temperature	0°C ~ 40°C
Operating-Humidity	85% Max. relative humidity
Dimensions	330(L) x 260(W) x 160(D)mm
Weight	Approx. 3.6kg (battery included)
Power Source	1.5V "C" x 8 Alkaline Batteries
Accessories	Test leads(see page 47) Instruction manual Battery



CE

6220 EL

FEATURES

- Microprocessor technology ensures high performance accuracy and reliability.
- Fully programmable via tactile key pad.
- Direct readout of disconnection, time or current.
- Voltage measured during test.
- Housed in a heavy duty carry case.
- Suitable for all industrial, mining and domestic environments.
- Display can be customized for special orders.
- Indicate Voltage and Trip Current/Time.
- Use binary principle.
- True resistor switching.
- IEC 1010-1 CAT III

SPECIFICATIONS

Rated Tripping Current at 317V	1000mA (2000mA on special orders)
Lowest Resolution	1mA
System Voltage	230 / 380 / 550V / 50Hz
Maximum Trip Time	99.99s
Highest Resolution	10ms
Typical Accuracy	
Rated Trip Current	±1%rdg ±2dgt
Voltage Range	±1%rdg ±1dgt
Trip Time	±1%rdg ±2dgt
Operating-Temperature	0°C ~ 40°C
Operating-Humidity	80% Max. relative humidity
Dimensions	330(L) x 260(W) x 160(D)mm
Weight	Approx. 3.7kg (battery included)
Power Source	1.5V "C" x 8 Alkaline Batteries
Accessories	Test leads Instruction manual Battery



STANDARD

3 PHASES INDUSTRIAL EARTH LEAKAGE TESTER and 3 PHASE PRESENCE & ROTATION INDICATOR



CE

6221 EL

This Test Instrument is a **combined** 3 Phases Presence and Rotation Indicator combined with a 3 Phases Industrial Earth Leakage Tester.

When utilized as a 3 Phase Presence and Rotation Indicator, the instrument does not use the batteries and can still be utilized if the batteries are not present or if the batteries are too low.

The 3 phase Presence and Rotation Indicator which is inside the 6221 EL, takes it's power from the circuit under test.

The Earth Leakage can be utilized on a Single Phase (up to 317Vac Line to Earth) or a **3 Phase Powered System** (550V Line to Line or Phase to Phase) with a protective Earth conductor.

The Earth Leakage requires batteries.

When utilized on a single phase, ensure correct connection between Line and Earth before using the tester.

When utilized on a **3 Phase Powered System**, the instrument is then utilized as a 3 Phases Presence and Rotation Indicator and a Earth leakage tester (selecting which phase to Earth will be utilized for the ELCB test).

When utilized on a 3 Phases Powered System, this instrument is a rotary field indication instrument which display all three phases by lighting up it's corresponding Lamp. It display the rotation (clockwise or anti-clockwise) on a LED.

To test the tripping time or the tripping current of a Earth Leakage Circuit Breaker, make sure to connect the earth wire.

This instrument represents the quickest and easiest way for servicing, repairing and electrical maintenance of 3 phase system with earth leakage.

With this equipment, you can, before connecting Load to Supply: On the supply side; Quickly verify the presence of the three Phases on a 3 Phases Power System.

Confirm the Phase Rotation on a Powered 3 Phase System.

Test the Tripping (disconnection) current and time of the protections.



FEATURES

- Indicates Phase Rotation.
- Indicates Phase Presence.
- TEST for Disconnection Sensitivity.
- Indicates Battery Status.
- TEST for Disconnection Time.
- Measure Voltage Phase to Earth.
- Select One of 3 Phase to test ELCB.
- Color Coded test Leads.
- Phase Presence Indication from as low as 100Vac.
- Works from 8 x C size 1.5VBattery.
- Very Low Consumption.
- Fused Earth Leakage Tester .
- Lightweight, Robust & Compact.
- ELCB Works 50Vac to 330Vac 50Hz / 60Hz.
- Led indication of Voltage on ELCB.
- Phase Rotation and Presence does not require battery to indicate.
- IEC/EN 61010-1 CAT III 550V

SPECIFICATIONS

Determination of the Phase Presence

Nominal Voltage for Phase Presence Indication (the voltage required for the neon lamps L1, L2, L3 to lit up)..... From 100Vac to 450Vac.

Frequency Range From 10Hz to 400Hz.

Determination of the Phases Rotary Field Direction:

Direction (the voltage required to have the direction LEDs L1-L2-L3 or L2-L1-L3 to indicates)... From 100 to 450Vac.

Frequency Range From 2Hz to 400Hz.

Protection

OverLoad..... 550V (between all terminals)

Over Voltage Class III - 450V towards ground.

Earth Leakage

Current Settings 999mAac / 50Hz -60Hz

Current Selection Knob

Phase Start Selection(*) 0° and 180°

Over-Temperature Protection(*) Yes

Phase Polarity Trip Indicator(*) Yes

Operating Voltage (L-E) 110Vac to 317Vac

(*)Referenced to Earth

Timer Resolution 1mS (Max Time = 99.99S)

Timer Accuracy 1mS ±4mS

Current Accuracy ±3% ±4mA

Current Resolution 1mA

Voltmeter Accuracy (50Hz) 50-350 Vac = ±3%±2V

350-550Vac = ±7%±3V

Voltmeter Resolution 1V

Maximum Current Specified at 317Vac / 50Hz - 60Hz

Batteries 8 x C batteries

Bat OK Led = Vbat >9V

Dimensions: 330(L) x 260(W) x 160(D) mm

Weight: 3.85 kg (battery included)

Operating temperature Range: -15 °C to + 55 °C

Storage Temperature: -20 °C to + 70 °C



Development in Progress

6230 ER

FEATURES

- High performance and accurate measurements of Earth Resistance, Ground Resistivity, as well as Resistance and Continuity.
- High performance integrated circuits and microprocessor for accurate and rapid display of readings.
- Automatically selected inside for the use of 2,3 or 4 poles method.
- Synchronous demodulator, active filter and plenty of opto-coupling to limit the noise influence.
- Auto power off after 5 minutes.
- Battery OK Indicated with LED.
- Capacity of measuring very low earth resistance with good resolution of 1mΩ.
- Voltage presence alarm of 20Vac or higher.
- Manually or automatically stopped after 60 Sec.
- Shock Resistance, Water and Dust Proof with strong case.
- Meets the international requirements of SABS0142, IEE Wiring Regulations, VDE413, DIN57413.

SPECIFICATIONS

Resistance Measurement Type (Number of PEGs)	2 poles 3 poles 4 poles
Resistance Test Currents (mA)(Square)	2-10-50
Measuring Ranges	Earth Resistance : 0-2.000Ω 0-20.00Ω 0-200.0Ω 0-2000Ω 0-20.00KΩ Earth voltage : 0-200Vac
Accuracy	Earth Resistance 2% F.S. : 25°C±5°C 80% RH Max. Earth Voltage of F.S. : ±1%
Noise Dependence (if < 20V Peak to Peak)	< 1.5% F.S.
Dielectric (50/60 Hz) stress	2000V
Current Frequency Accuracy	±0.5%
Current Frequency	128Hz ±1%
Protection of the Current Generator	Fused
Dimensions	330(L) x 260(W) x 160(D)mm
Weight	3.1kg (battery included)
Power Source	1.5V "C" x 8 Alkaline Batteries
Accessories	Test leads Instruction manual Batteries





CE

6237 DLRO

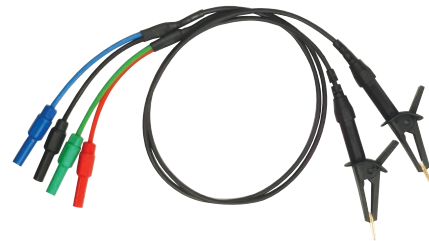
Test leads

The **6237 DLRO** is a "full feature professional instrument". The **RUGGED and "O-RING" SEALED** Digital Low Resistance Ohm and Contact Meter is specially designed to **measure very low resistance** accurately and give the result directly on the **large and clear LCD**. The 6237 DLRO makes measurements by passing a **constant current** through the device under test (generally a conductor, contact or low resistance) and measuring the voltage across it. The Low Resistance is then calculated by ohm's law.

This superb instrument is powered by rechargeable battery. It is **supplied complete** with instruction manual and test report / QA **certificate**. This ensure that every product is not just fully functional and calibrated after the assembly lines, but also within tight specifications tolerances before leaving the **strict quality control** of Standard Electric Works.

It has visual LED checks for excessive; potential lead resistance (R_p) and current lead resistance (R_c). Should the instrument become too warm, the temperature sensor will shut down the current ($I_{sc}OFF$).

This instrument is indispensable to laboratory applications and to field applications to measure bonding joints, circuit breakers contact resistance, fuse resistance, testing earth bonds in mines, rail bond when a rail is used as part of a communication system or for power transmission, Checking the plating quality on PCBs, contacts of relays, continuity or ring circuits and of protective conductors etc...

FEATURES

- Microprocessor controlled.
- Measures down to $1\mu\Omega$.
- 6 ranges from 2.000m Ω to 200.0 Ω .
- Maximum resolution of $1\mu\Omega$.
- Three test current with over- temperature protection.
- Four terminals measurement.
- Protection against inadvertent connection to over-voltage.(crow bars for current and vorage)
- Clear & large L.C.D.
- Potential lead resistance, current lead resistance checks.
- "Full Featured" EnerSave™ inside.
- EnerSave™ AUTO-HOLD.
- EnerSave™ AUTO-OFF.
- Rechargeable battery operated, robust & compact.
- Indicators shows if reading may be invalid (R_p , R_c).
- "O-Ring" sealed case.
- Portable - Rechargeable battery.
- IEC/EN 61010-1



SPECIFICATIONS

Low Resistance Ranges / Resolution	0-2.000m Ω / $1\mu\Omega$ 0-20.00m Ω / $10\mu\Omega$ 0-200.0m Ω / $100\mu\Omega$ 0-2.000 Ω / 1m Ω 0-20.00 Ω / 10m Ω 0-200.0 Ω / 100m Ω
Accuracy	0-2.000m Ω : $\pm(5\%+5dgt)$ 0-20.00m Ω : $\pm(5\%+4dgt)$ 0-200.0m Ω : $\pm(4\%+3dgt)$ 0-2.000 Ω : $\pm(3\%+2dgt)$ 0-20.00 Ω : $\pm(3\%+2dgt)$ 0-200.0 Ω : $\pm(3\%+2dgt)$
Test Current (dc)	2.000m Ω to 200.0m Ω : $1A\pm2\%$ 200.0m Ω to 20.0 Ω : $100mA\pm2\%$ 200.0 Ω : $10mA\pm2\%$
Accuracy of DC Voltmeter	0-200.0m Ω : $\pm(3\%+2dgt)$ 0-2000m Ω : $\pm(0.8\%+2dgt)$ 0-20.00 Ω : $\pm(0.7\%+2dgt)$ 0-200.0 Ω : $\pm(0.7\%+2dgt)$ 0-2000 Ω : $\pm(0.7\%+2dgt)$
Maximum Output Voltage (C1-C2)	10V
Power Source	Rechargeable
Dimension	330(L) x 260(W) x 160(D) mm
Weight	Approx. 3.2kg(battery included)
Accessories	Test leads (AC-34) Instruction manual Rechargeable batteries



STANDARD

HIGH VOLTAGE PROXIMITY DETECTOR

CE



270 HP

United States Design Patent : US D474, 705 S

FEATURES

- Microprocessor controlled.
- 10 voltage settings : 240Vac, 2kV, 3.3kV, 6kV, 11kV, 22kV, 33kV, 66kV, 132kV, and 275kV (11 for special).
- Ultra high bright LEDs indication.
- Loud high pitch sound indication.
- Self test & diagnostic circuitry.
- Friendly priority alert reporting.
- Fail safe design.
- High impact nylon type casing.
- Different alerting sound & light.
- Built-In sunrise (stick) link adaptor.
- D.S.P. pass-band filter (40 to 70Hz).
- Suitable for indoor and outdoor use.
- Detect low voltage on any systems.
- Low battery indication.
- All OK indication (Hard & Software).
- Weight :Approx. 550g.
- Meets EN61326 EN55011 EN61000-3-2
EN61000-3-3 EN61000-4-2 EN61000-4-3
EN61000-4-4 EN61000-4-5 EN61000-4-6
EN61000-4-11



The **NEW Smart-Prox** 270 HP from SEW is a Smart High Voltage Proximity detector. It is **Microprocessor Controlled**. The design is exclusive and has no equivalent to date.

It has ten voltage detection settings from **240Vac to 275kVac** as standard and can accommodate up to 11 settings for custom applications.

The **Smart-Prox** 270 HP is a "**Fail-Safe**" Design with an Internal Pickup Sensor coupled to a Permanent Diagnostic Test Pulsing System, a Rotary Sensitivity Selector, a Powerful Red Flash Light and a High Pitch Buzzer, all driven independently from each other. **A very easy to understand "Priority Alert" Reporting System (Audio and Visual) let the user know if an ac, 50 or 60Hz signal has been detected (Buzzer and Red Light, BOTH "ON") by Smart-Prox, if batteries are Low (morse type pulsating sound, no light) and if, during standby, everything is OK with the Hardware AND Software (Quick Sound followed by Quick Red Flash).** With the **Smart-Prox** 270 HP, *physical contact with Electrical conductors is not necessary* when testing for live lines. **Smart-Prox** works by *proximity to AC*.

Its sensor senses the radiated field which surrounds AC live conductors. **That Sensed signal is filtered digitally by the Microprocessor, using Digital Signal Processing techniques.**

Only relevant AC signals frequencies are accepted by the microprocessor to alert the user, thus decreasing the false alerts from statics or electrical noise.

Detection distance of a 240Vac single wire is $\pm 10\text{cm}$, with a bunched neutral and earth cable, as in a flexible cable, the distance is reduced to 5cm.

Checking or proofing the tester is done automatically by the Diagnostic Test Pulses. The **Smart-Prox** 270 HP has a special circuitry which test itself entirely. The Diagnostic Circuitry test the following: The Sensor plate, the wiring from the main PCB to the sensor, the wiring from the sensor to the Test Pulse circuit, the microprocessor program, the Buzzer, the Red Light and of course, the working of the sensing pulses. Once all these are correct, and only then, **Smart-Prox** report on its status by using a quick Buzz, followed by a quick Red flash, indicating **EVERYTHING IS WORKING OK - WAITING FOR AC**.

As you can see, the indications are also tested and the user can determine that everything is ok.

The **NEW Smart-Prox** 270 HP is enclosed into a water tight Nylon, flame retardant material enclosure and uses 3 x 1.5V "C" size batteries.

Some of the typical uses are : identify and check live cables ; find fault in flexible cables ; check earth equipment ; service neon lightning ; trace live wires ; detect residual or induced voltages. For example, faults in damaged flexible cables are found by applying low voltage to each conductor. Earth the remainder and moving the tester along the cable until the change in condition is obtained. (Flexible cables which are used in mining and building industries, are readily repairable when the break in the cable is located.)

When testing for high voltage, the rotary switch (attenuator) is used to identify and differentiate various HV live cables. *The tester must be used in conjunction with a long and insulating rod when measuring high voltage (kV).*



STANDARD

HIGH VOLTAGE PROXIMITY DETECTOR



275 HP

United States Design Patent : US D474, 705 S

FEATURES

- Sealed by "O" rings
- 8 voltage settings : 240Vac, 2kV, 6kV, 11kV, 22kV, 33kV, 132kV, and 275kV
- High bright LEDs visual indication
- Sound indication
- Easy-to-proov method
- Self-test selection
- Use 3 x 1.5V "C" batteries
- High impact nylon casing
- Non-contact work by proximity
- Compatible with most link sticks
- Light weight, robust, & compact
- Suitable for indoor and outdoor use
- Detect low voltage on any systems
- Easy access to batteries
- No special parts needed
- Simple and efficient to use
- Weight :Approx. 500g.
- Meets EN61000-3-2 EN61000-3-3 EN61326-1
EN55011 EN61000-4-2 EN61000-4-3 EN61000-4-4
EN61000-4-5 EN61000-4-6 EN61000-4-11

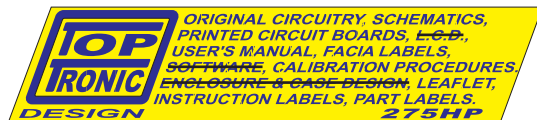

LIMITATIONS OF USE :

It is recommended that the 275 HP is not used in HV yards of mixed voltages. In the presence of mixed voltages, the tester can become unreliable.

Problems can arise when the tertiary circuit of a 275/133/11kV transformer is tested. The electric field of the HV and MV bus bars can trigger the detector when it is about 3m above the ground. This is common with most of the electric field voltage detectors, and the users should be aware of it. The tester can pick up adjacent circuit to the one being tested and indicate the wrong information to the user.

The SEW 275 HP is a high voltage proximity detector. It has eight voltage detection settings from 240Vac to 275kVac. The 275 HP consists of an internal pickup sensor plate, a sensitivity selector, a visual and a sound annunciator. With the 275 HP, physical contact with electrical conductors is not necessary when testing for live lines. This tester works by proximity.

Its sensor senses the radiated field which surrounds live conductors. Radiated field strength increases with voltage and decreases quickly with distance or earth shielding. The radiated field from a cable of closely bunched conductors supplied by three phase power tends to cancel (See "Limitations of use" paragraph). Detecting distance of a 250Vac single live wire is approximately 10cm. With a bunched neutral and earth cable, as in a flexible cable, the distance is reduced to 5cm.

Some of the typical uses are : identify and check live cables ; find fault in flexible cables ; check earth equipment ; service neon lightning ; trace live wires ; check high frequency radiation ; detect residual or induced voltages. For example, faults in damaged flexible cables are found by applying low voltage to each conductor. Earthing the remainder and moving the tester along the cable until the change in condition is obtained. (Flexible cables which are used in mining and building industries, are readily repairable when the break in the cable is located.)

When testing for high voltage, the rotary switch (attenuator) is used to identify and differentiate various HV live cables. The tester must be used in conjunction with a long and insulating rod when measuring high voltage (kV). However, the 275 HP is a non-contact tester and it is advised that the tester should never come into contact with cables (kV) as this tester is merely a non-contact AC proximity tester.

Checking or proofing the tester is easy. Switch the sensitivity to 240V and place the dome against a low voltage live conductor or rub the dome with a cloth or against an item of clothing as this generates a static DC which triggers the detection of circuit. The light and beeper should go "on" as if a live wire is being.

Expected test results (laboratory testing) :

Range	Operated from
240V	Variable from 80V or depending on the type of source
2kV	250V
6kV	500V
11kV	1000V
22kV	1500V
33kV	4000V
132kV	8000V
275kV	22kV

Typical observation of test results made in the field :

Range	Min. Detection Voltage (MDV)	MDV as % of Line Voltage
11kV	1kV	9.1%
22kV	2kV	9.1%
33kV	3.1kV	9.4%
132kV	12.5kV	9.5%
275kV	22.5kV	8.2%



276 HD

This Model 276HD detects the presence of voltage in AC lines. An elongate insulation rod permits checking of high tension circuits at safe distance for voltage. The equipment is compact, light weight, and easy to handle, and is also available for voltage detection in low-tension circuits.

FEATURES

- **Telescopic, compact, light-weight**

276HD :

length : From 354mm to 1005mm
Weight : Appox. 150g.

276SHD :

length : From 230mm to 880mm
Weight : Appox. 140g.

They are easy to handle, and handy to carry.

- **High-voltage detectable**

The equipment, whether in stretched state is available for voltage detection in high-tension circuits (3.3kV, 6.6kV and 24kV) whether the wires involved are naked or insulated.

- **Low-voltage detectable**

The equipment can be used for voltage detection in low-tension circuits (80V ~ 600V) by holding the nameplate portion of the detecting head. Before-use check can easily be done by plugging in an AC 100V plug socket, without using a tester.

- **Easy to recognize indication**

Intermittent lighting in red of a high intensity light-emitting diode and intermittent audible sound of an electronic buzzer are readily recognizable at a full daylight, noisy location.

- **Waterproof**

The detecting head, being tightly enclosed, is free from any trouble due to dust, dirt, water or the like.

- Meets EN61010-1 EN50081-1 EN55082-1
En55022 EN61000-4-2 EN61000-4-3

RATINGS AND SPECIFICATIONS

- **Working voltage range :**

H.V. : 3kV~24kV AC..... hold grip portion to detect.

L.V. : 80V~600V AC..... hold nameplate portion to detect.

- **Frequency : 50Hz / 60Hz**

- **Operation Test : (Initial voltage)**

(a) When stretched, hold the grip portion.

Put the sensing tip in contact with the voltage : 250V AC \pm 50V the LED and buzzer should work.

(b) When retracted, hold the nameplate portion.

Put the sensing tip in contact with the voltage : 80V AC or below the LED and buzzer should work.

- **Operation start distance**

Distance at which operation starts when front metal is brought near ϕ 5mm O.C. wire with grip portion held by hand.

Where 24kV / ϕ 3mm (voltage to ground)abt 20cm.

Where 6.6kV / ϕ 3mm (voltage to ground)abt 3cm.

Where 3.3kV / ϕ 3mm (voltage to ground)abt 1cm.

- **Dielectric Strength :**

(a) Between Sensing tip ~ Grip portion : 50kV AC, 1 min
(The detector has to be stretched)

(b) Between Sensing tip ~ Nameplate portion : 4kV AC, 1 min.

- **Construction :**

Waterproof (detecting head impervious to water).

- **Insulation resistance :**

Measure the insulation resistance with the high voltage insulation tester.

The areas we measure are the same as Dielectric strength test.

(a) Between Sensing tip ~ Grip portion : 1kV
(The detector has to be stretched)

The insulation resistance has to be more than 2000 M Ω .

(b) Between Sensing tip ~ Nameplate portion : 1kV

The insulation resistance has to be more than 2000 M Ω .

- **Leakage Current Test :**

Put high voltage on the parts listed below.

(a) Between Sensing tip ~ Grip portion : 50kV AC, 1 min
(The detector has to be stretched)

The leakage current has to be 100 uA or less than 100 uA.

(b) Between Sensing tip~Nameplate portion : 4kV AC, 1 min.

The leakage current has to be 100 uA or less than 100 uA.

- **Working temperature range : -10° C ~ +50° C**

- **Battery : 3 button-cells LR44(1.5V)**



285 HD

285 HD High Voltage Detector is primarily used to detect the presence of an alternating field.

It shows identification of AC voltages. 285 HD has a large LCD that is housed in an ABS enclosure. 285 HD can be attached to the cable by a large metal clip and can be secured with a cable tie. The high voltage detector senses the radiated magnetic field surrounding the cable and shows a LIVE warning sign on the LCD.

FEATURES

- Three different ranges of identification of AC voltage :
285-A HD : 3~7 kV
285-B HD : 6.6~11 kV
285-C HD : 10~22 kV
- The LCD will "flash continuously" for high voltage testing.
- Physical contact with electrical conductors is not necessary when testing for live wires.
- The 285 HD senses the radiated field that surrounds live conductors.
- Radiated field strength increases with voltage and decreases quickly with distance.
- Large LCD.
- Continuous monitoring.
- Easy to install.
- No batteries required.
- Weight : Approx. 80g.
- Meets EN 61326-1
EN 55011
EN 61000-3
EN 61000-4

APPLICATION

- Identify and check live cables.
- Check live wires at high voltage.

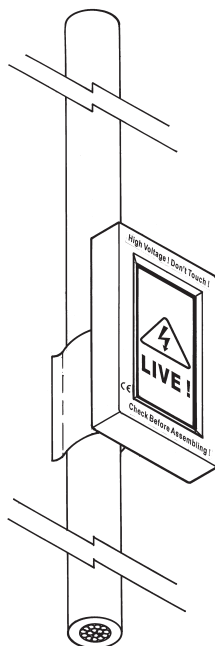

PD-40AM

PD-40AM is a high voltage probe meter. It measures positive polarity DC voltages up to 40kV.

It consists of 2 kinds of contact tips, a meter, a test clip for the ground and a high quality enclosure.

The enclosure has very good insulation properties. It is lightweight and rugged.

2 kinds of contact tips are available.

One is a round needle tip for normal use.

Another is a special flat spring type for CRT anode.

PD-40AM is typically used to measure high voltages in TV sets, power supplies and instruments in laboratories. Before taking any measurements, first connect the alligator clip of this probe to earth ground and make sure connection is proper.

SPECIFICATIONS

Input Impedance	600 MΩ
Attenuation Ratio	40000 : 1
Accuracy	DCV (0 ~ 20kV) ±2% DCV (20kV ~ 40kV) ±3%
Max.Working Voltage	DC 40kV
Operating Temperature	0°C ~ 50°C
Storage Temperature	-10°C ~ 60°C
Cable Length	1 m
Weight	Approx.400g
Note	For Positive Polarity only Not for Microwave ovens

- Meets IEC/EN 61010-1
IEC/EN 61010-2-031

CE

288SVD

FEATURES

- Warning Proximity of AC Voltage (240V~50kV).
- Water Proof (sealed to Ip65).
- Easy to wear on Body, Belt, Helmet.
- Ultra High bright LED indication.
- High Pitch Sound indication.
- Test & Diagnostic Circuitry.
- Friendly Priority Alert Reporting.
- Circuit Test Function.
- High impact type casing.
- Different Alerting Sound & Light.
- Can be adapted to Sunrise (stick).



The **Body-Prox** 288SVD is a **Personal Safety Voltage Proximity Detector**.

It is a designed to alert the user that they are approaching live equipment where dangerous voltage is present.

The **Body-Prox** tells the user to stay at a safe distance from live equipments, therefore it protect and safeguard people from approaching dangerous Live High Voltage equipment or cable.

Live Alert is shown by a ultra bright LED on the front panel and heard via a **Buzzer**.

When Live equipment is detected near the user's body, the user will be alerted of the PROXIMITY OF LIVE equipment by the AUDIO ALERT (beeping) and the VISUAL ALERT (LED flashing) wice per second.

The 288SVD is an ultra low consumption product and can be used for months without replacing the 9V battery.

It can be tested by pressing both front panel buttons to proof the tester is working properly.

Should the battery become too low, a low battery indication will beep the buzzer and lit the led shortly every 5 seconds.

The **Body-Prox** is water proof and can be used in all weathers.

It has no voltage selection and the user does not need to know how to operate complicated test equipment. It is designed to be simple to use. It only require to proof it's good working condition.

This is done by simply depressing the two push buttons situated on the front panel.

A very easy to understand "Priority Alert" Reporting System (Audio and Visual) let the user know if an ac signal has been detected in the proximity (Buzzer and Red Light, BOTH "operates shortly twice per second").

Body-Prox, alert if battery is Low (Buzzer and Red LED, BOTH "operates shortly every 5 seconds) per second".

- Removable neck belt.
- Suitable for indoor and outdoor use.
- Detect voltage on any systems.
- Low Battery Indication.
- All OK test indication.
- Ultra low power consumption.
- Meets EN61326 EN55011 EN61000-3-2 EN61000-3-3 EN61000-4-2 EN61000-4-3 EN61000-4-4 EN61000-4-5 EN61000-4-6 EN61000-4-11

Body-Prox FACTS & TIPS

- Worn on the outside of clothing facing the direction of movement.
- Safety Warning for Utility, Industrial or Rescue Personal.
- Clip to Belt, Pocket, Safety Helmet or any other safety gear.
- Worn around the neck using the removable neck lace/strap.
- Rugged for outdoor use.
- All Circuit integrity Test Buttons.
- Small and Light in weight.
- Never Sleeps - It is always "ON" and ready to warn you of danger.
- Alerted before touching.
- Detect the presence of High Voltage in the vicinity.
- **Body-Prox** is a necessary tool for the protection of human life.
- Used by non electrical employees which must work around HV or in an environment unknown to them.
- Does not require any knowledge of electricity to use.

GENERAL DESCRIPTION

The **288SVD** consist of an internal pickup AC sensor plate, a test (oscillator) and diagnostic circuit, an adjustable threshold comparator, a sound annunciator (buzzer), a visual indicator (super high bright led) and a 9V battery, all enclosed into the robust "beeper" style case. The enclosure has a built-in clip to be able to be attached on the outer garments / external clothing or belt.

PRINCIPLE OF HOW IT WORK

The **288SVD** detects AC voltages using it's internal AC sensor plate. The AC sensor plate pick up part of the radiated electric field in volts per meter (V/M).

The electric field is amplified and processed by the internal circuitry and once the processed signal is above the threshold, triggers the input of a integrated circuit, which start the oscillator for the buzzer and led. The Buzzer beeps and Led lit intermittently at a rate of 2 beeps/flash per second. The "Self-test" diagnostic is actioned by depressing simultaneously both push button on the front panel. The battery monitoring is always ON. Please see the priority of alert on the front panel.

It is recommended that when the 288SVD is used in HV yards of mixed voltages: In the presence of mixed voltages, it could become difficult to determine exactly which source has been detected or which source created the alert. Always treat all sources as LIVE.



PD-20 PD-20S and PD-28 are high voltage probes. They measure both AC and DC voltages with your multimeter. They consist of 2 kinds of contact tips, a test clip for the ground, a set of test leads for multimeter and a high quality enclosure. The enclosure has very good insulation properties.

They are light-weight and rugged.

2 kinds of contact tips are available.

One is a round needle tip for normal use.

Another is a special flat spring type for CRT anode.

Before taking any measurements, first connect the alligator clip of this probe to earth ground and make sure connection is proper.



CE

PD-20S

● For scope.

PD-20

- PD-20 and PD-28 have the same shape and color but different specifications.
- Meets IEC/EN 61010-1
IEC/EN 61010-2-031

SPECIFICATIONS
PD-20 PD-20S

Input Impedance	500 MΩ
Attenuation Ratio	1000 : 1
Accuracy	DCV (0 ~ 20kV) ±1%, DCV (20kV ~ 30kV) ±2% ACV (0 ~ 20kV) typically ±5% at 60 Hz
Max.Working Voltage	30kV DC or 20kV AC
Operating Temperature	0°C ~ 50°C
Storage Temperature	-10°C ~ 60°C
Cable Length	1 m
Weight	Approx. 260g

●Note: PD-20 is a high voltage probe that is used with DMM

PD-28

Input Impedance	1000 MΩ
Attenuation Ratio	1000 : 1
Accuracy	DCV (0 ~ 20kV) ±1%, DCV (20kV ~ 40kV) ±2% ACV (0 ~ 28kV) typically ±5% at 60 Hz
Max.Working Voltage	40kV DC or 28kV AC
Operating Temperature	0°C ~ 50°C
Storage Temperature	-10°C ~ 60°C
Cable Length	1 m
Weight	Approx. 260g

●Note: PD-28 is a high voltage probe that is used with DMM



STANDARD

HIGH VOLTAGE MULTIFUNCTION PHASING STICKS



PC 7K
PC11K
PC22K
PC33K
PC44K

FEATURES

- Designed to Exceeds VDE 0681 part 5.
- No user's assembled parts.
- Dual Color Coded Scale (% , Vac).
- Neon indicator lit when >1200Vac.
- Light weight, Robust & Compact.
- Carry Case included.
- Compare between Phases.
- Measure and test Phase to Earth.
- High Quality Fiberglass wound Rod.
- Self Powered operation -No Battery-.
- DC version available.
- Measure Phase to Phase.
- Hi immunity to interference fields.
- Suitable for indoor and outdoor use.
- Current is limited to ± 1 milli-ampere
- Grounded or Ungrounded systems.
- Voltage Color Coded -O-Y-G-B-R.
- Factory Test Certificates.
- Meets IEC 61481:2001



This NEW PC range of High Voltage Multifunction Phasing Sticks are: all-in-one, a Phase Comparitor with color coded scale indication, a Voltage Detector with Neon Indication and a Scaled Voltmeter. They are available in five models for applications up to 44kV systems (6.6kV, 11kV, 22kV, 33kV and 44kV).

The NEW PC range of Multifunction Phasing Sticks utilizes a long established technique to detect and measure High Voltages and perform phasing tests. These Dual Poles instruments incorporates modern, high quality glass fibre front end, composite polyurethane main body molding to give tough and very light weight construction and superior safety features. They have Analog Color Coded Dual Scales and Neon indication.

They are not just VDE0681 part 5 compliant and IEC1243-2. They are practical and efficient. Because of their multifunction capabilities, you do not need to buy separates instruments, You can therefore stay within your budget without compromise.

They are supplied complete with instruction manual and two FACTORY test report certificates and, optionally, a calibration certificate. They are housed in a superb High Quality modern Plastic Case with shock absorbing foam. The New PS range is self powered and does not requires battery. They are suitable for indoor and outdoor use (in dry weather). They do not require dismantling or re-assembling and do not have any user's assembled parts, so eliminating the risks of assembly mistake and accidents during High Voltage Work in a breakdown situation.

The NEW PC range does not have any dangerous, user selectable/assembled metal parts exposed to high voltage, thus, the user can't be exposed to lethal voltage while handling or testing with the new PC range. They are over-designed for increased user protection and are lighter than any other sticks on the market today. The indicator has been screened for high immunity to interference fields.

They determine the voltage and positively identify phases up to 44kV. We have measuring ranges from 6.6kV up to 44kV systems but others voltages can be manufactured on request.

Fiberglass is of hot stick quality and tested to IEC specs (100kV / 300mm for 1 min). All front end (resistors) are encapsulated. These analog Multifunction Phasing Sticks are ideally suited for testing of grounded or ungrounded systems. Important applications include checking voltage fuses, testing for correct phase connections, and for absence of high voltage on de-energized lines or apparatus. The Dual scale read direct (no multiplier) in kVac or in % of full scale and is color coded (Green = in phase Red = out of phase). A Bright neon is included on the scale for easy visibility indoor and it has dual purpose. The neon is also a detector and start to lit when the voltage across the poles is higher than 1200Vac. In case of unlikely failure of the analog scale indicator, the neon can be used as voltage detector.

Our Manufacturing process and method ensure that every product is not just fully functional and calibrated after the assembly lines, but also within tight specifications tolerances before leaving the strict quality control of the factory. They are then re-checked, re-calibrated (optionally) and certified by an independent recognized authority. All our PC testers are versatile and single range for added safety. They have low metal content and nylon is used wherever possible. They are equipped with two fixed-length poles connected by a strong flexible, insulated cable. Hand guards are standard on all models. They are easy to handle, light weight, well insulated and designed to ensure maximum operator safety.

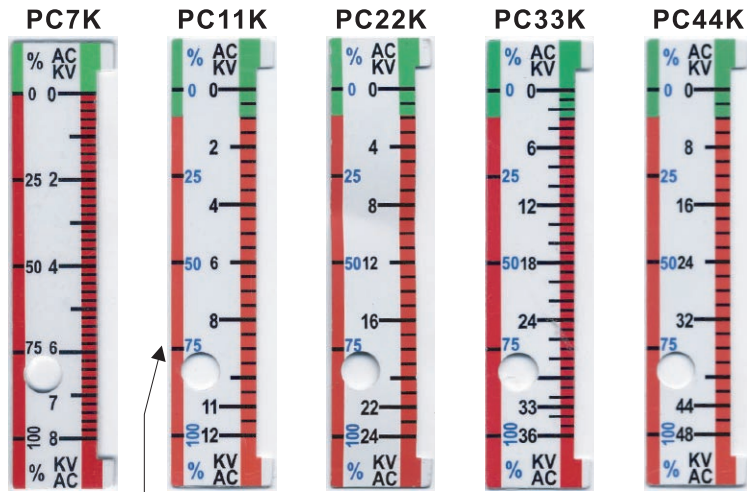
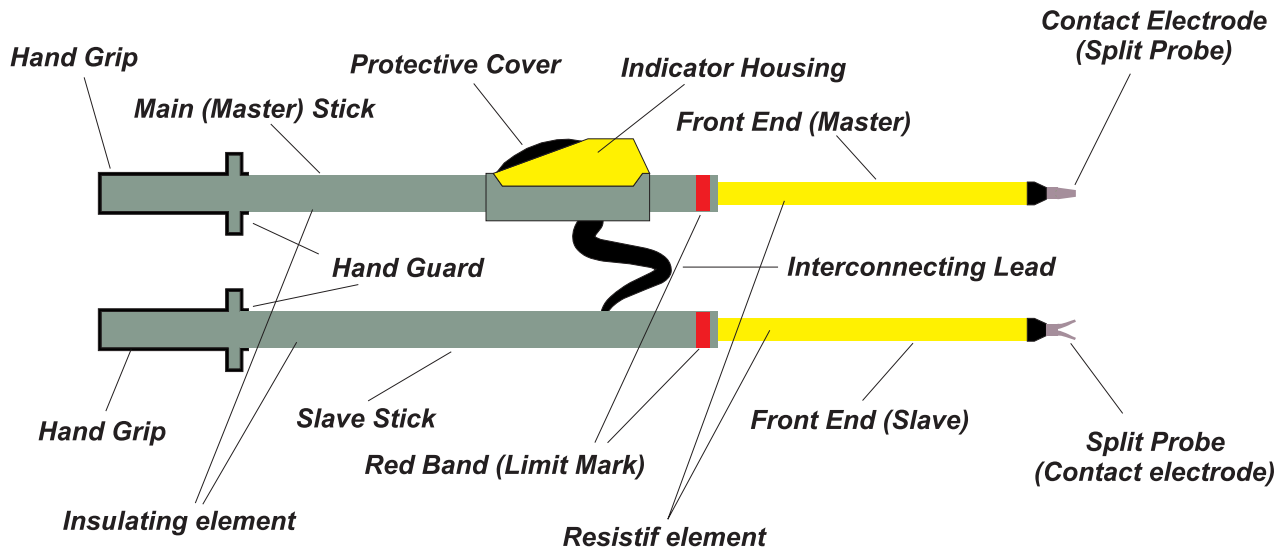
Scales (samples)

Neon Indicator
Accessories

Range of Models

- Models are available to cover system voltages from 1kV to 44kV @50 or 60Hz.
- Contact the factory for information on models suitable for other Voltages.
- All models have Neon and Analog Panel Meter Indicators.
- The following models are available as standard Instruments :

Model	System Voltage Voltage	Full Scale Voltage	Maximum Voltage
PC7K	6.6kV	8kV	9kV
PC11K	11kV	12kV	15kV
PC22K	22kV	24kV	30kV
PC33K	33kV	36kV	40kV
PC44K	44kV	48kV	55kV

SPECIFICATIONS

Electrical	PC7K	PC11K	PC22K	PC33K	PC44K
Total Resistance	3.95MΩ	6.78MΩ	13.5MΩ	20.1MΩ	27MΩ
Response time	<1Sec	<1Sec	<1Sec	<1Sec	<1Sec
Neon Threshold	1.2kV	1.2kV	1.2kV	1.2kV	1.2kV
Neon Lit Fully @	1.5kV	1.5kV	1.5kV	1.5kV	1.5kV

Mechanical	PC7K	PC11K	PC22K	PC33K	PC44K
Lenght of Handle	765mm	765mm	765mm	765mm	765mm
Lenght Front End	340mm	340mm	460mm	610mm	760mm
Total Lenght	1.105M	1.105M	1.225M	1.375M	1.525M
Total Weight	1.2kG	1.2kG	1.3kG	1.4kG	1.5kG

Handle Materia Composite Material with Polyurethane
Front Endl Fiber Glass Wound Tubing

Environmental

Operating temperature : -25° C to +55° C
Operating Humidity : 20 to 96% RH.

Due to our policy of constant improvement and development, we reserve the right to change specifications without notice.

Contact the factory for the latest product specifications.



STANDARD CAPACITIVE HIGH VOLTAGE DETECTORS (CONTACT)



CE

213 HVD

FEATURES

- Excellent Shock Resistance.
- Rugged Nylon moulding.
- Auto-ON (when Voltage Detected).
- Very Good Drop Resistance.
- Good Vibration Resistance.
- Loud Sound Alarm Indication.
- Built-in Proving and self-test circuit.
- High Bright Color Coded LEDs.
- Works from normal 9V battery.
- Interchangeable Contact Electrode.
- Use in All Weather Conditions.
- Compatible with all link sticks.
- Lightweight, Robust & Compact.
- Models available from 11kV to 132kV.
- Suitable for indoor and outdoor use.
- Self (Auto-ON) or Manual Arming.
- Easy access to batteries.
- Customized threshold on demand.
- Auto-Off (if no voltage detected).
- Meets IEC 61243-1
 - IEC 60068-2-2
 - IEC 60068-2-6
 - IEC 60068-2-32
 - IEC 60529



This family of Capacitive High Voltage Detectors have been designed to meet the latest IEC standards.

Our HVD are self starting and automatically activated when the High Voltage is applied to the contact electrode.

They can also be manually armed before use by depressing the "TEST/ARMING" button.

These detectors are intended for use on sinusoidal (50 or 60Hz) High Voltage Systems.

Models are available to cover systems voltage from 11kV to 132kV.

Our Detectors are utilized to determine if a system is live or not, so that it maybe safely earthed/grounded.

All our models are designed for outdoor, but can be utilized indoor and in all wheather condition.

This family of capacitive High Voltage Detectors are housed in a rugged, reinforced nylon moulded casing and are shock drop and vibration resistant.

Non-standard threshold voltages can be customized to suit applications requirements

The HVD have a low battery detection which inhibit manual arming when the battery is too low.

The Nylon case is easy to clean and maintain and the HVDs are supplied with the cleaning kit.

A visual indication shows when the HVD is armed. When armed, the Green Leds flashes about twice per second.

When HV is detected, the Red leds flashes about twice per second and the buzzer also buzz intermittently.

A range of accessories is available.

Dimensions: 300(L)x100(W)x100(D)mm

Weight: Approx 550g (battery included)

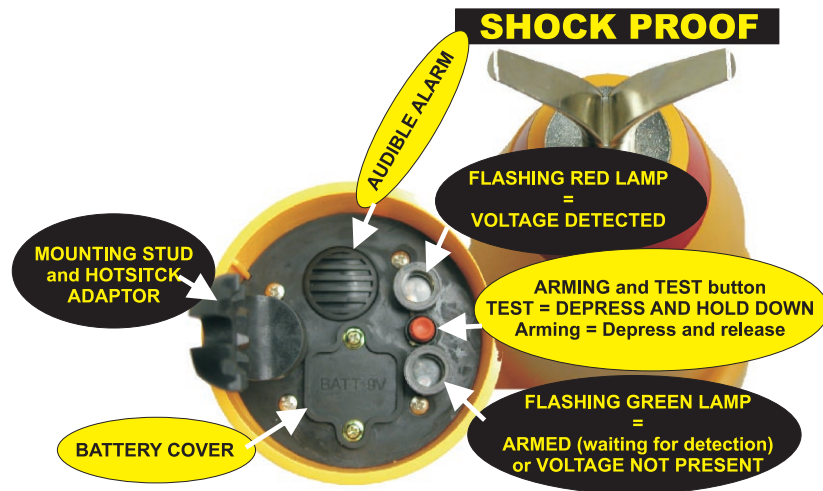

CLEAR INDICATION OF VOLTAGE DETECTED



STANDARD CAPACITIVE HIGH VOLTAGE DETECTORS (CONTACT)

PART#	213HVD	214HVD	215HVD	216HVD	217HVD	218HVD	219HVD
System Voltage	11kV	33kV	66kV	132kV	11/33kV	44/132kV	66/132kV
Threshold Set within Range	1.65kV To 4.4kV	4.95kV To 13.2kV	9.9kV To 26.4kV	19.8kV To 52.8kV	3.3kV To 4.95kV	6.6kV To 19.8kV	13.2kV To 29.7kV
Response Time	<1 Sec	<1 Sec	<1 Sec	<1 Sec	<1 Sec	<1 Sec	<1 Sec
Auto-OFF	±3Min	±3Min	±3Min	±3Min	±3Min	±3Min	±3Min
Bridging Protection	YES	YES	YES	YES	YES	YES	YES
Spark Protection	YES	YES	YES	YES	YES	YES	YES
Battery Low	<7V	<7V	<7V	<7V	<7V	<7V	<7V
Threshold	3.02kV	9.07kV	18.15kV	36.3kV	4.12kV	13.2kV	21.45kV
Battery Current	<30mA	<30mA	<30mA	<30mA	<30mA	<30mA	<30mA
Green = Armed	YES	YES	YES	YES	YES	YES	YES
Red = V Detected	YES	YES	YES	YES	YES	YES	YES
Test / Arming Button	YES	YES	YES	YES	YES	YES	YES

HOT STICK



CE

HS-120

- The Complete Household Service Extraction Kit.
- The hot stick consists of - 3 x 1.8 meter sticks
1 x 1.2 meter head section complete with universal sunrise fitting.
- 1 x carry bag.
- IEC 60855





STANDARD OVERHEAD LINES CONTACT VOLTAGE DETECTOR & LOW VOLTAGE INDICATOR



LVD-415

FEATURES

- Requires No Batteries.
- Every Circuit is Doubled.
- Buzzer Indicates Voltage Detected.
- Led Indicates Voltage Detected .
- Neon Scale Indicates Voltage.
- Dual HBC Fuses.
- High Grade Fiber Glass Probes.
- Super Polished Fiber Glass.
- High Strength Connecting Cord.
- CAT IV 450V.
- Heavy Duty Rated.
- Replaceable tips.
- Choice of tips available.
- Light Weight.
- Small Storage Space.
- Strong Strength Reliefs.
- Double Poles Non Polarized.
- Suitable for 45 to 70Hz Networks.
- Contact Detector Type.
- Passive Circuitry.
- Fiber Glass 1.6mm - CU 35um PCB.
- Super Bright Neon Lights and Leds.
- Ergonomically Designed.



Have you ever try to measure the voltage between overhead lines or between Line and Earth ?

Did you do it using a normal meter with normal test leads? Were you scared while doing it? I bet you were and you have all the right reasons to be.

This is why the Double Check (LVD415) was initially designed. Double Check is a **Visual Voltmeter** with a **Neon Lights scale** which lit proportionally to the voltage between the sticks, it also a **Detector** with bright **Led** and loud **Sound** indication on each side.

The Double check has both sides identical, with at least, everything **Doubled**.

It's a **CAT.IV** Double pole Measurement System which has it's poles long enough to be clear of the lines while testing them.

These poles are made out of highly insulating **Super Polished High Grade Fiber Glass**. Their color is highly visible and it's strong and durable.

Both poles are electrically connected by a **High Strenght Spiraled and Highly Insulated Cord** which is **securely held by customized strenght reliefs** . Each circuit is fully fused by **High Breaking Capacity Fuses**.

Safety has been the most important factor while developing this product.

Each circuit is present on the left pole as well as on the right pole.

Each circuit works independently from each other.

The cord connecting the poles is doubled as well, so each circuit has it's own conductor going from one pole to the other.

The LVD415 has **Visual Voltage Indicators (neons)** which lit when the voltage between the poles is superior or equal to 110V, 220V, 280V and 415Vac.

Length:1000mm

Weight:Approx.670g

Some applications for the Double Check are:

Measure and confirm Overhead Voltage between Lines in all Safety due to the clearance from the probes contacts.

This is done when, for example, using a bucket on a truck, then from the bucket, you can reach all the phases and check voltage between each phases.

Check Voltage Presence between two conductors or between Phase and Earth.

Measure and Detect Voltage between Bus bars and between Bus bar Earth.

Use where you are not comfortable with your normal test leads.

Tips can be changed for different types.

Available tips: Fork type, Piercing trough Insulation, Cone, Flat tip, Other on on Demand.

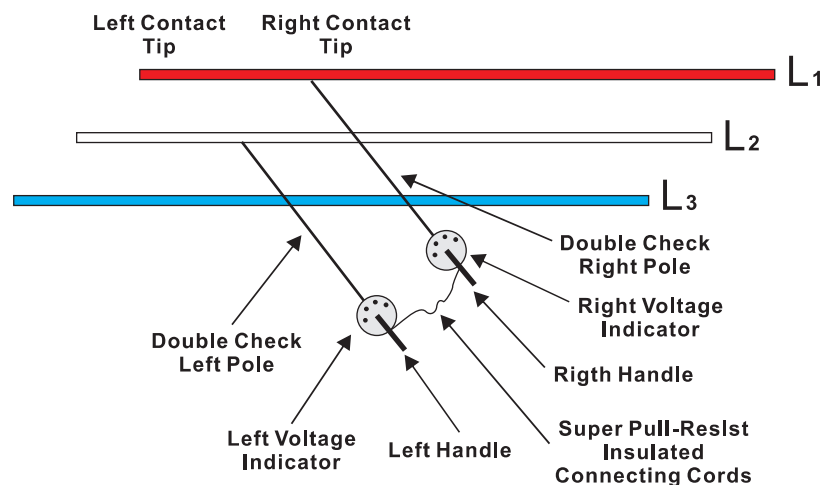



STANDARD SOUND LEVEL METER

LIGHT METER



CE

2310 SL

FEATURES

- Max. & Min. function.
- Over & Under range indication.
- 4-digit LCD display with bar graph.
- Frequency weighting characteristic for 2 times per second.
- AC signal output.
- Low battery indication.
- IEC 651 Type 2 & ANSI S1.4 Type 2.

SPECIFICATIONS

Measuring Ranges	Lo : 32dB~80dB Med : 50dB~100dB Hi 80dB~130dB
Accuracy	±1.5dB (at Reference Range)
Reference sound level & frequency	94dB , 1kHz
Resolution	0.1dB
Detector-indicator characteristic	Fast : 125mS Slow : 1 S
Analog signal output	AC 1Vrms for each range
Dimensions	235(L) x 58.4(W) x 34(D)mm
Weight(prox)	220g(battery included)
Power source	9V(6F22.006p)x1 battery
Accessories	Instruction manual Adjusting bar Battery Sponge cover

CE



2330 LX

FEATURES

- Wide range for measurements as high as 40000 lux and 4000 fc.
- 0.01 lux and 0.001 fc resolution for accurate low light level measurements.
- Light sensor cover is included for preserving sensor life.
- Auto off function.
- Data hold and peak hold function.
- Low battery indication.
- Over range indication.
- Auto-ranged.
- Manual-ranged.
- Calibration mode is provided.
- 9V battery system.
- Selection key for lux and fc.
- The spectral sensitivity close to CIE photopic curve.
- Ideal tool for workplace, clean-room and computer room light testing.
- Video, photographic, office, classroom, and architectural uses.

SPECIFICATIONS

Measuring Ranges	39.99 / 399.9 / 3999 / 39990 lx 3.999 / 39.99 / 399.9 / 3999fc
Resolution	0.01 lx - 10 lx 0.001 fc - 1 fc
Accuracy	±(3%rdg+5dgt) Calibrated to standard incandescent lamp, 2856°K.
Display	40000 - conut LCD
Photosensor	Silicon photodiode
Operating / Storage conditions	0°C - 40°C < 80% RH -10°C - 50°C < 70% RH
Power source	9V(6F22.006p)x1 battery
Dimensions	194(L) x 62(W) x 34(D)mm
Weight(prox)	245g(battery is included)
Accessories	Instruction manual Battery Carry case



180 CB

AMPLIFIER PROBE(180 CB-A)

- The Amplifier Probe is designed to identify and trace wires or cables within a group without damaging the insulation.
- Work with any Tone Generator to identify wires.
- Volume control for increased sensitivity and adjustable to suit work environment.
- Recessed ON/OFF button prevents battery drain.
- Power supply is in any 9V battery with a life of Approximately 100 hours.
- A plug receptacle is designed for head set or hand set.

TONE GENERATOR(180 CB-G)

- Tone Generator is great tool for locating and identifying cable pairs or individual conductors.
- Besides providing tone generator, tone generator serves as a continuity and polarity tester.
- Test results are displayed by a three-colored led.
- Meets EN55011 EN61000-4-4 EN61000-4-5 EN61000-4-6



190 CBI

- 190 CBI and 191 CBI have the same shape but different specifications.

190 CBI is an easy tool to find the circuit breaker or fuse supplying electrical power to an outlet or lighting fixture. Just plug the transmitter into the outlet.

Use the receiver to scan the circuit breaker panel box. An audible tone will be clearly heard when the right circuit breaker is scanned.

It is not necessary to shut off power to find the right circuit breaker or fuse.

190 CBI is an ideal tool for both automated office environments where disruption of power is not practical, as well as in residential applications.

The plug of transmitter is changeable.

The plug of transmitter could be changed for customers' requirement from different countries.

Quickly identifies and locates 110 ~ 125 VAC circuit breakers and fuses.

It is not necessary to interrupt power.

Audible tone generated when matching breaker is located.

It is an easy way to identify location of circuit breaker on the circuit breaker panel box which is connected to a specific outlet.

SPECIFICATIONS

Model	190CBI	191CBI
Operation Voltage	110 ~ 125 VAC	220 ~ 240 VAC
Operation Frequency	50 / 60 Hz	
Transmitter Power	Powered by wall outlet	
Receiver Power	9V battery	
Accessories	Instruction manual 9V battery	
Safety Standard	IEC/ EN 61010-1:01	



STANDARD

FUSE, CIRCUIT BREAKER and FAULT FINDER



CE

188 FFF

The 188FFF is a Fuse and Fault Finder which comprises of two parts:
The Receiver and the Transmitter.

The Transmitter, draws a current from the mains supply circuit to which it is connected to. The Signal Current from the Tx is at about 10kHz. The Transmitter is powered by the mains and requires no batteries.

The 10kHz signal current generated by the Transmitter is then searched (sniffed) by the Receiver to detect the Fuse, Circuit Breaker or the faulty circuit.

The Receiver is a tuned circuit which has its center frequency tuned to about 10kHz. The sensor is located in the tip of the Receiver. The amplitude of the received signal is shown on a bar-graph type Leds.

The more Leds ON, the stronger the signal.
The Receiver uses one 9V battery.

SPECIFICATIONS

Receiver

Tuner circuit mid Frequency	10kHz
Bar Graph Leds	9
Battery indicator Led	1
On button	1
Off button	1
Buzzer	1
Auto-off (Min) approx	1
Power source	9V(6F22 006P)x1
Dimensions	200(L)x50(W)x40(H)mm
Weight	112g(battery included)
Material	Polycarbonate/ABS

FINDING CIRCUIT BREAKER

Use the tip of the Sniffer to scan the circuit breakers. Please note that the Sniffer is designed to be held vertically for the vertical circuit breakers and horizontally for the horizontal circuit breakers

MAKE SURE ALL THE CIRCUIT BREAKERS ARE ON

Now, for example, start scanning from the top left row, then go down etc..., But you can scan the breakers in any order. While you are scanning, observe the bar-graph and listen to the buzzer.



The Circuit breaker which supply the Transmitter circuitry is the one, which, when pointed out by the tip, has the most LEDs lit on the bar-graph and the fastest buzz.

FINDING EARTH FAULT

To find an earth fault, or the trace faulty wire, you must connect the transmitter in serie with the fault. For example, say, you have a short between Line and Earth, but you don't know where the short is.

Connect the Transmitter, using an adaptor, in serie, in the line. If the Protection device trips, then you will have to bypass the protection device for the duration of this test. Use the optional leads for this use.

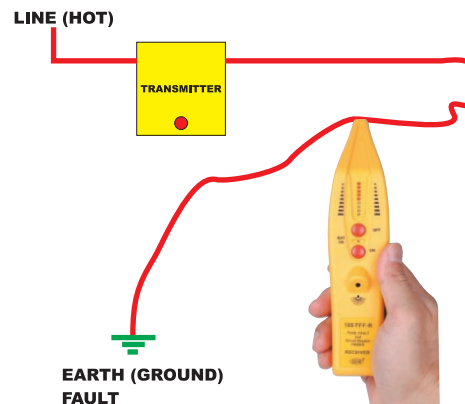

Transmitter

Working Voltage	110 to 240 Vac (50/60Hz)
Frequency of Sourced signal	10 kHz
Dimensions	60(L)x50(W)x30(H)mm
Weight	134g
Connection	Specify type of plug

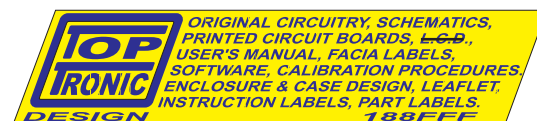

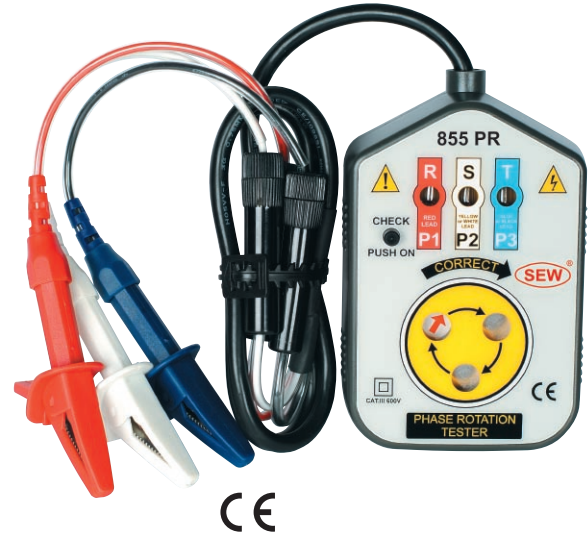
ST-850

855 PR

FEATURES

- Two functions in one unit.
It is designed to check phase sequence. Lamps provided on the unit will tell you whether phase is open or which phase is open at a glance.
- Large size alligator clips.
Can easily hold terminals of switchboards.
- Highly reliable.
Allow you to check a wide range of 3-phase power source from 90V to 600V.
- Special test lead length are available on request.

- Sealed against dust, the unit ensures highly dependable and trouble-free performance.
- Functional design.
Small, lightweight and portable. Designed for maximum ease of operation.
- Safety design.
No exposed metal parts. Safety features are incorporated throughout, including the pushbutton switch designed to minimize damage due to negligence.

SPECIFICATIONS

Model	ST-850	855 PR
Voltage	90V-600V AC	200V-600V AC
Frequency Response	50/60 Hz	50/60 Hz
Storage Temperature & Humidity	-20°C~60°C at 90% max. relative humidity	-20°C~60°C at 90% Max. relative humidity
Operating Temperature & Humidity	-10°C~40°C at 80% max. relative humidity	-10°C~40°C at 80% Max. relative humidity
Dimensions	134(L) x 85(W) x 45(D)mm	134(L) x 85(W) x 45(D)mm
Weight	Approx. 510g	Approx. 530g
Cord	1.1m each of red(R), White(S) and black(T) cord	1.1m each of red(R), White(S) and black(T) cord
Accessories	Instruction manual Vinyl case	Instruction manual Vinyl case
Safety Standard	IEC 1010 CAT.II	EN61010-1 EN61010-2-31 CAT III 600V

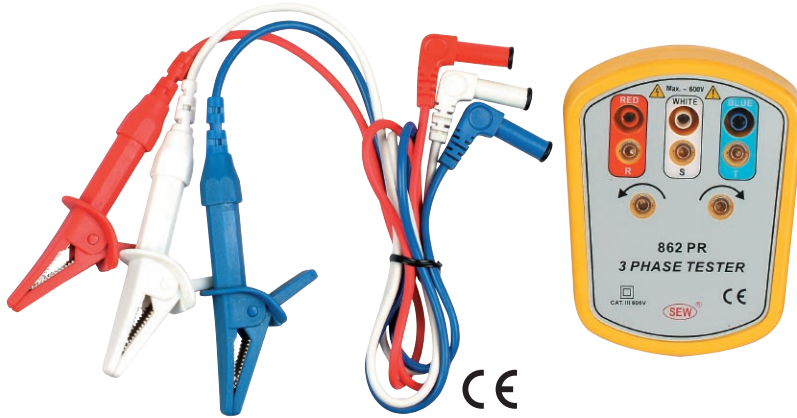
862 PR
FEATURES

- Two functions in one unit.
Including open phase and phase sequence.
- Large size alligator clips.
Can easily clip on switch-boards terminals.
- Highly reliable.
Identifies 3 phase sequence and open phase check.
- Functional design
This model is ideal for installing conveyor lines, pump systems and interconnected drivers.
- Water proof.
- EN 61010-1 CAT III 600V/CAT IV 300V
- Special test lead length are available on request.

SPECIFICATIONS

Input Voltage	100-600V AC
Frequency Range	45-70 Hz
Circuit Structure	All electronic (not mechanical)
AC Power Consumption	Approx. 7mA per phase rotation fired indicator
Dimensions	102(L) x 78(W) x 32.5(D)mm
Weight	862 PR : 115g test leads : 97g Total : 212g
Accessories	Test leads (AL-34) Vinyl case Instruction manual

863 PR
FEATURES

- Two functions in one unit.
Including open phase and phase sequence.
- Large size alligator clips.
Can easily clip on switch-boards terminals.
- Highly reliable.
Identifies 3 phase sequence and open phase check.
- Functional design
This model is ideal for installing conveyor lines, pump systems and interconnected drivers.
- EN 61010-1 CAT III 600V
- Special test lead length are available on request.

SPECIFICATIONS

Input Voltage	100-600V AC
Frequency Range	45-70 Hz
Circuit Structure	All electronic (not mechanical)
AC Power Consumption	Approx. 7mA per phase rotation fired indicator
Dimensions	102(L) x 78(W) x 32.5(D)mm
Weight	Approx. 228g
Accessories	Vinyl case Instruction manual



888 PMR

FEATURES

- Indicates Phase Presence.
- Indicates Phase Rotation.
- Indicates Motor Rotation / Wiring.
- Indicates Battery Status.
- Phase Rotation and Motor Rotation Indication works from as low as 1Vac.
- Small and rugged enclosure.
- Phase and Motor Rotation Indicator works from as low as 1Vac.
- Color Coded test Leads.
- Phase Presence Indication from as low as 100Vac.
- Very Low Consumption.
- Fused.
- Lightweight, Robust & Compact.
- Works from 2 Hz to 400Hz Sine.
- IEC/EN 61010-1 CAT III 600V

With this equipment, you can, before connecting Supply to Load :

- On the supply side ;
Quickly verify the presence of the three Phases on a 3 Phases Power System.
Confirm the Phase Rotation on a Powered 3 Phase System.
- On the Motor Side (Load) ;
Confirm the Phase Rotation on a unpowered 3 Phase Motor 3 Phases Alternator.
Confirm that each winding is connected to the terminals of the motor, when the rotation Leds light up.

The **888 PMR** is a 3 Phases Presence and Rotation Indicator combined with a 3 Phases Motor Rotation Tester.

It can be utilized on a **3 Phases Powered System** (the supply side) or on a **Three Phases Unpowered Motor** (the load side) without having to worry about damage to the tester.

When utilized on a **3 Phases Powered System**, the instrument is then utilized as a 3 Phases Presence and Rotation Indicator. When utilized on a **Three Phases Unpowered Motor**, the instrument is then utilized as a 3 Phases Motor Rotation Tester. When utilized on a 3 Phases Powered System, this instrument is a rotary field indication instrument which display all three phases by lighting up it's corresponding lamp. It display the rotation (clockwise or anti-clockwise) on a LED. When utilized on a 3 Phases Unpowered Motor, it is also possible to determine the motor connections U, V, W without a live circuit to avoid subsequent damages of e.g. pumps to reversed motor rotation. It displays the rotation (clock-wyze or anti-clock-wyze) on a LED.

This instrument represents the quickest and easiest way for servicing, repairing and electrical maintenance of 3 phase systems and 3 phase rotating machinery.

SPECIFICATIONS

Phase Presence	From	100Vac
Nominal Voltage for Phase	To	600Vac
Presence Indication (The voltage required for the neon Lamps L1, L2, L3 to light up).	Freq	10-400Hz
Determination of Phase	From	1Vac
Rotation Field Direction	To	600Vac
	Frequency	2-400Hz
Determination of Motor Connections (requires > 1/2 turn of the shaft)	From	1Vac
	To	600Vac
	Freq	2-400Hz
Maximum Current Consumption		18mA
OverVoltage CLASS III		600V
Over Load between all terminals		600V
Battery OK goes off when battery voltage		<6.5Vdc
Power Source		9V(6F22.006P) x1 battery
Dimensions		153(L)x72(W)x35(D) mm
Weight		Approx.185g (battery included)
Accessories		Test leads(AL-34) Vinyl case Instruction manual Battery

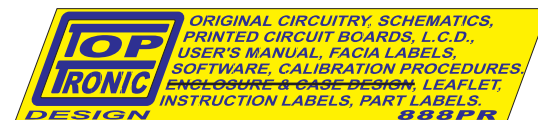



STANDARD

LCD 3 PHASE PRESENCE & ROTATION INDICATOR TESTER

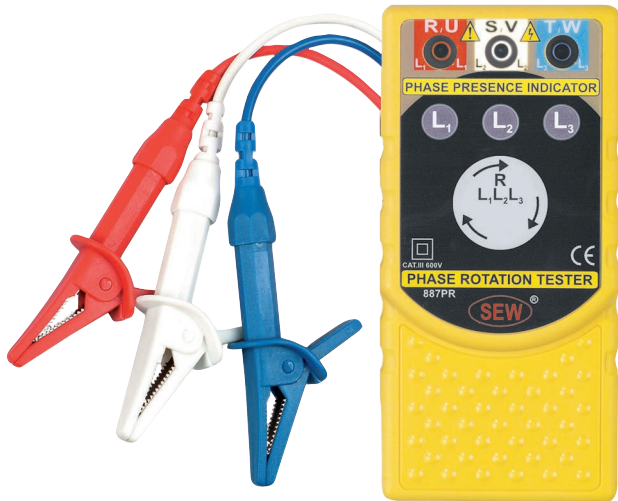

CE

887 PR

The **887 PR** is a 3 Phases Presence and Rotation Indicator.

It does not need any battery as it derives its power from the system under test.

It can be utilized on a 3 Phases Powered System without having to worry about damage to the tester or the system.

Once connected to a 3 phase power system, it indicates the Phase presence by showing its corresponding LCD symbol. It displays the rotation (clockwise or anti-clockwise) On the LCD.

This instrument represents the quickest and Easiest way for verifying the presence and rotation of a 3 Phase System.

You can, before connecting Supply to Load, and from the supply side;

Quickly and easily verify the presence of the three Phases on a 3 Phase Power System.

Confirm the Phase Rotation on a Powered 3 Phase System.

3 Phase Presence Indication circuit:

This circuit uses the LCD to indicate if a phase is present.

These LCD indicators will light up when the voltage across any two phases are more than 40Vac.

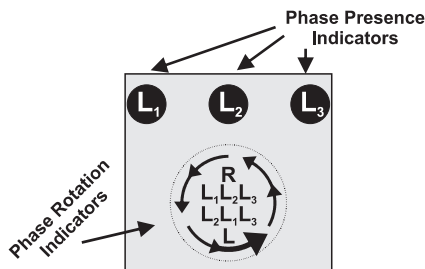

3 Phase sequence Rotation indicator circuit:

This circuit has also a LCD indication This product does not require any battery as it takes its power from the circuit under test.



FEATURES

- Indicates Phase Rotation.
- Indicates Phase Presence.
- Requires NO BATTERY.
- Phase Rotation Indicated on Large Liquid Crystal Display.
- Small and Rugged Enclosure.
- Phase Presence Indicated on Large Liquid Crystal Display.
- Color Coded Test Leads.
- Phase Presence Indication from as low as 40Vac to as High as 700Vac.
- Fused.
- Lightweight, Robust & Compact.
- IEC/EN61010-1 61010-2-032 CAT III 600V

SPECIFICATIONS

ELECTRICAL

Determination of the Phase Presence

Nominal Voltage for Phase Presence Indication (the voltage required for the LCD L₁, L₂, L₃ indicators to come on)..... From 40Vac to 700Vac.

Frequency Range From 15Hz to 400Hz.

Determination of the Phases Rotary Field Direction:

Direction Indication by LCD Display (the voltage required to have the LCD Direction Arrows to indicates and the L₁L₂L₃ or L₃L₂L₁ indicators to show) From 40 to 700Vac.

Frequency Range From 15Hz to 400Hz.

Protection

OverLoad..... 700V (between all terminals)

Over Voltage Class III - 700V towards ground.

Fuses..... 2 x 3mA, 6 x 31mm, HBC,600V Fast Blow

General

Current Consumption Max 3 mA.

MECHANICAL

Dimensions..... 153(L)x72(W)x35(D)mm

Material..... Polycarbonate /ABS

Weight (less carrying case)..... 158.5g

Display..... Liquid Crystal Display

ENVIRONMENTAL

Operating temperature Range : 1 °C to 55 °C not in full sun!!!

Storage Temperature : -20 °C to 70 °C

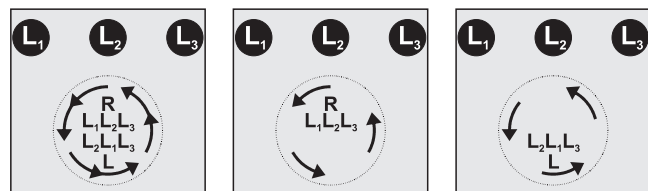

Everything is "ON" to Show all segments

3 Phases Presence Rotating Right L₁L₂L₃

3 Phases Presence Rotating LEFT L₂L₁L₃

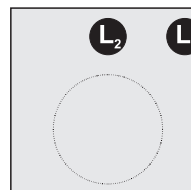

L1 Missing No Rotation Indication

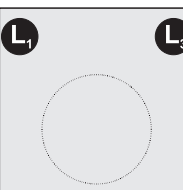

L2 Missing No Rotation Indication

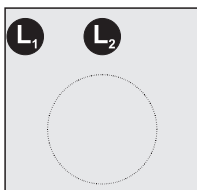

L3 Missing No Rotation Indication



CE **ST-860**



ALS-1

FEATURES

- Three functions in one unit.
Including open phase, phase sequence and motor rotation indication.
- Large size alligator clips.
Can easily clip on switch-boards terminals.
- Highly reliable.
Identifies 3 phase sequence and open phase check.
- Functional design
This model is ideal for installing conveyor lines, pump systems and interconnected drivers.
- EN 61010-1 CAT III 600V

SPECIFICATIONS

Input Voltage	100-600V AC
Frequency Range	45-70 Hz
Circuit Structure	All electronic (not mechanical)
Power Requirement	9V DC (006P) battery
Power Consumption	Consumption current approx. 14mA of motor rotation field tester
AC Power Consumption	Approx. 7mA per phase rotation filed indicator
Dimensions	153(L) x 72(W) x 35(D)mm
Weight	Approx. 200g (battery included)
Accessories	Test leads (AL-34) Vinyl case Battery Instruction manual

With the aid of the AC line separator, the Ac current from any appliance can be determined by plugging the appliance directly into the separator. By doing so, you are able to separate the neutral from hot/live conductor.

The advantage of using this separator allows the appliance to remain plugged in, thus providing a constant current and separation of the conductors.

The AC line separator provides two clamp positions :
(1) x1. which is used for direct reading and.
(2) x10. which is used for actual readings multiplied by a factor of 10.

The separator also includes a voltage check function. The opening specification is 0.95" x 0.95" (24mm x 24mm)

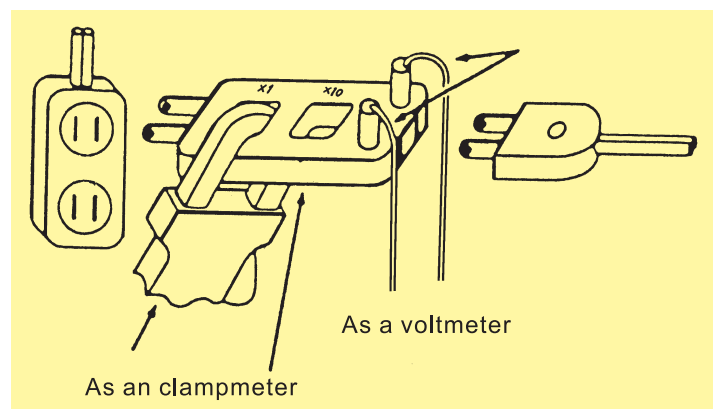



STANDARD

ROTARY SCALE CLAMP METER



FEATURES

- Designed for measuring AC current, AC voltage, resistance and DC voltage (only ST-375)
- Rotary scale which presents only one scale in windows at one time to avoid any possible reading errors.
- Pointer lock function freezes the reading in dimly lit or hard to reach places.
- Ω range ideal for checking the continuity of relays, transformers and motor coils.

- TAUT BAND movement (1010 CL)

Model	ST-375	ST-600	ST-1000
ACA	▲300A	▲600A	▲1000A
ACV	▲600V	▲600V	▲750V
DCV	▲75V	—	—
Ω	▲2K Ω	▲2K Ω	▲2K Ω
POINTER LOCK	▲	▲	▲

SPECIFICATIONS

Model	ST-375	ST-600	ST-1000(1010 CL)
ACA	6/15/60/150/300A ±3% of F.S.(50/60Hz)	6/30/60/300/600A ±3% of F.S.(50/60Hz)	10/30/100/300/1000A ±3% of F.S.(50/60Hz)
ACV	300/600V ±3% of F.S.	150/300/600V ±3% of F.S.	150/300/750V ±3% of F.S.
DCV	75V ±3% of F.S.	—	—
Ω	2K Ω ±3% of F.S. length	2K Ω ±3% of F.S. length	2K Ω ±3% of F.S. length
Frequency Response	50/60Hz for ACA 6A 50-400Hz for ACA 15/60/150/300 A	50/60Hz for ACA 6A 50-400Hz for ACA 30/60/300/600A	50/60Hz for ACA 10A 50-400Hz for ACA 30/100/300/1000A
Dimensions	230(L) x 72(W) x 37(D)mm	230(L) x 72(W) x 37(D)mm	227(L) x 73(W) x 33(D)mm
Conductor Size	38mm Max.	38mm Max.	52mm Max.
Weight (Battery Included)	420g Approx.	420g Approx.	460g Approx.
Accessories	Test leads (AL-26) Carrying case Instruction manual	Test leads (AL-26) Carrying case Instruction manual	Test leads (TEL-AL11-1+OTL-1000) Ohm test probe Carrying case Instruction manual
Safety Standard	EN 61010-1 EN61010-2-32 CAT II 600V	EN 61010-1 EN61010-2-32 CAT II 600V	—

ST-2600
3800 CL
3810 CL
TRUE RMS
FEATURES

- Full autorange for V, A and Ω functions.
- Data hold function freezes the reading in dimly lit or hard to reach places.
- Low battery indication.
- Built-in buzzer for continuity test.
- Safety design throughout with no exposed metal parts. Shielded banana plugs and recessed input terminals.
- Ohm function ideal for checking continuity of relays, transformers and motor coils.

SPECIFICATIONS

Model	ST-2600 (Auto-Ranges)	3800 CL (Auto-Ranges)	3810 CL (Auto-Ranges)
ACA	400A $\pm(2.0\%rdg+3dgt):50/60Hz$	400/1000A $\pm(1.5\%rdg+3dgt):40-500Hz$	400/1000A $\pm(1.5\%rdg+3dgt):40-500Hz$
ACV	400/600V $\pm(1.2\%rdg+3dgt):40-500Hz$	400/600V $\pm(1.0\%rdg+3dgt):40-500Hz$	400/600V $\pm(1.0\%rdg+3dgt):40-500Hz$
DCA	—	400/1000A $\pm(1.5\%rdg+3dgt)$	400/1000A $\pm(1.5\%rdg+3dgt)$
DCV	—	400/600V $\pm(0.75\%rdg+3dgt)$	400/600V $\pm(0.75\%rdg+3dgt)$
Ω	4K Ω $\pm(1.5\%rdg+3dgt)$	2000 Ω $\pm(1.0\%rdg+3dgt)$	2000 Ω $\pm(1.0\%rdg+3dgt)$
Buzzer Sounds	<100 Ω	<100 Ω	<100 Ω
Conductor Size	27mm Max.	40mm Max.	40mm Max.
Low Battery Indication			
Dimensions	197(L) x 65(W) x 33(D)mm	255(L) x 80(W) x 35(D)mm	255(L) x 80(W) x 35(D)mm
Weight (Battery Included)	Approx. 250g	Approx. 420g	Approx. 420g
Power Source	9V (6F22.006p) x 1 battery	9V (6F22.006p) x 1 battery	9V (6F22.006p) x 1 battery
Accessories	Test leads (AL-26) Carrying case Instruction manual Battery	Test leads (TEL-AL11-1) Carrying case Instruction manual Battery	Test leads (TEL-AL11-1) Carrying case Instruction manual Battery
Safety Standard	EN 61010-1 EN61010-2-32 CAT II 600V	EN 61010-1 EN61010-2-32 CAT III 600V	EN 61010-1 EN61010-2-32 CAT III 600V

ST-3600

ST-3602

ST-3620
FEATURES

- Display 3½ digit, liquid crystal display with maximum reading of 1999.
- Over range indication : "1" is displayed on highest digit.
- Low battery indication : "B" sign appears on the display.
- Response time : approx. 1 second.
- Data hold : for all ranges.

SPECIFICATIONS

Model	ST-3600	ST-3602 (Auto-Ranges)	ST-3620
ACA	200/1500 ±(2%rdg+4dgt) (40Hz-1KHz)	200/1500 ±(2%rdg+4dgt) (40Hz-1KHz)	200/1500 ±(2%rdg+4dgt) (40Hz-1KHz)
ACV	200/750 ±(1.5%rdg+2dgt) (40Hz-1KHz)	200/750 ±(1.5%rdg+2dgt) (40Hz-1KHz)	200/750 ±(1.5%rdg+2dgt) (40Hz-1KHz)
DCA	200/1500 ±(2%rdg+4dgt)	200/1500 ±(2%rdg+4dgt)	_____
DCV	20/200/1000 ±(1%rdg+2dgt)	200/1000 ±(1%rdg+2dgt)	_____
Ω	200/1500 ±(1.5%rdg+2dgt)	200/1500 ±(1.5%rdg+2dgt)	200 ±(1.5%rdg+2dgt)
Diode check	0-1500mV ±(1.5%rdg+2dgt)	0-1500mV ±(1.5%rdg+2dgt)	_____
Buzzer	_____	Resistance is less then 100Ω	Resistance is less then 30Ω
Peak Hold	_____	_____	V
Conductor Size	ø55mm Max.	ø55mm Max.	ø55mm Max.
Dimensions	245(L) x 70(W) x 41.7(D)mm	245(L) x 70(W) x 41.7(D)mm	245(L) x 70(W) x 41.7(D)mm
Power Source	9V(6F22) x 1	9V(6F22) x 1	9V(6F22) x 1
Weight (Battery Included)	480g Approx.	480g Approx.	480g Approx.
Operating Temperature	-10°C~50°C	-10°C~50°C	-10°C~50°C
Humidity	85%	85%	85%
Current Consumption	10mA Approx.	10mA Approx.	10mA Approx.
Accessories	Test leads (TEL-AL11-1) Carrying case Instruction manual Battery	Test leads (TEL-AL11-1) Carrying case Instruction manual Battery	Test leads (TEL-AL11-1) Carrying case Instruction manual Battery



CE

3900 CL

CE

3902 CL

CE

3904 CL
SPECIFICATIONS

Model	3900 CL	3902 CL	3904 CL
ACV	400.00mV ±(1.5%rdg+3dgt) 4.000/40.00/400.0/600V ±(1.0%rdg+3dgt) 40~500Hz	200.00mV ±(2.0%rdg+3dgt) 2.000/20.00/200.0/600V ±(1.5%rdg+3dgt) 40~500Hz	400.00mV ±(2.0%rdg+3dgt) 4.000/40.00/400.0/600V ±(1.5%rdg+3dgt) 40~500Hz
DCV	400.00mV/4.000/40.00/400.0/600V ±(0.75%rdg+2dgt)	200.00mV/2.000/20.00/200.0/600V ±(1.0%rdg+3dgt)	400.00mV/4.000/40.00/400.0/600V ±(1.0%rdg+3dgt)
ACA	400.0/2000A 0~1500A ±(2.0%rdg+4dgt) 1500A~2000A ±(2.5%rdg+4dgt)	200.0/2000A 0~1500A ±(2.0%rdg+4dgt) 1500A~2000A ±(2.5%rdg+4dgt)	400.0/2000A 0~1500A ±(2.0%rdg+4dgt) 1500A~2000A ±(2.5%rdg+4dgt)
DCA	400.0/2000A 0~1500A ±(2.0%rdg+4dgt) 1500A~2000A ±(2.5%rdg+4dgt)	200.0/2000A 0~1500A ±(2.0%rdg+4dgt) 1500A~2000A ±(2.5%rdg+4dgt)	400.0/2000A 0~1500A ±(2.0%rdg+4dgt) 1500A~2000A ±(2.5%rdg+4dgt)
Ω + Continuity	400.0Ω/4.000/40.00/400.0kΩ/4.000MΩ ±(1.5%rdg+3dgt) 40.00MΩ ±(2.0%rdg+4dgt)	200.0Ω/2.000/20.00/200.0kΩ/2.000MΩ ±(1.5%rdg+3dgt) 20.00MΩ ±(2.0%rdg+4dgt)	400.0Ω/4.000/40.00/400.0kΩ/4.000MΩ ±(1.5%rdg+3dgt) 40.00MΩ ±(2.0%rdg+4dgt)
Hz	4.000/40.00/400.0KHz/4.000/40.00MHz ±(1.0%rdg+2dgt)	2.000/20.00/200.0KHz/20.00MHz ±(0.5%rdg+2dgt)	4.000/40.00/400.0KHz/40.00MHz ±(0.5%rdg+2dgt)
Capacitor	—————	2.000/20.00/200.0nF/2.000/20.00/ 200.0uF/2.000mF ±(3.0%rdg+5dgt)	4.000/40.00/400.0nF/4.000/40.00/ 400.0uF/4.000mF ±(3.0%rdg+5dgt)
Bargraph	V	—————	—————
Display	3¾ (4000 counts)	3½ (2000 counts)	3¾ (4000 counts)
Auto-Ranges	V	V	V
Data Hold	V	V	V
Low Battery Indication	V	V	V
Auto Power-off	V	V	V
Max/Min. Mode	V	—————	—————
Relative Mode	V	—————	—————
Conductor Size	55mm Max.	55mm Max.	55mm Max.
Operating Temperature & Humidity	-10°C~50°C at <80% RH	-10°C~50°C at <80% RH	-10°C~50°C at <80% RH
Power Source	9V(6F22.006p) x 1 battery	9V(6F22.006p) x 1 battery	9V(6F22.006p) x 1 battery
Dimensions	265(L) x 100(W) x 42(D)mm	265(L) x 100(W) x 42(D)mm	265(L) x 100(W) x 42(D)mm
Weight	520g (battery included)	510g (battery included)	510g (battery included)
Accessories	Test leads (TEL-AL28-2) Carrying case Instruction manual Battery	Test leads (TEL-AL28-2) Carrying case Instruction manual Battery	Test leads (TEL-AL28-2) Carrying case Instruction manual Battery
Safety Standard	IEC/EN 61010-1 EN 61010-2-32 CAT III 600V		

FEATURES

- Designed for test AC current and AC voltage.
- AC current testing has 5 ranges.
- The minimum resolution of leakage current is 0.1mA.
- Frequency selection : 50/60 Hz and Wide.
- Data hold function.
- Maximum reading.
- Low battery indication.

SPECIFICATIONS
AC Current :

Ranges		Accuracy	
		50/60Hz	WIDE
200mA(0~199.9mA)		±(1.5%rdg+2dgt)	50/60Hz : ±(1.0%rdg+2dgt)
2A(0~1.999A)			40/1000Hz : ±(3.0%rdg+2dgt)
20A(0~19.99A)			
200A(0~199.9A)		±(2.0%rdg+2dgt)	50/60Hz : ±(1.5%rdg+2dgt) 40/1000Hz : ±(3.5%rdg+2dgt)
1000A	0~500A	±(2.0%rdg+2dgt)	50/60Hz : ±(1.5%rdg+2dgt) 40/1000Hz : ±(3.5%rdg+2dgt)
	501~1000A	±5.5%rdg	50/60Hz : ±5.0%rdg 40/1000Hz : ±10%rdg

Voltage :
3920 CL

Ranges	Resolution	Accuracy
AC 200V	0.1V	±(1.5%rdg+3dgt)
AC 600V	1V	±(1.5%rdg+3dgt)

3921 CL

Ranges	Resolution	Accuracy
AC 600V	1V	±(1.5%rdg+3dgt)
DC 600V	1V	±(1.0%rdg+2dgt)

(All at 23°C±5°C , ≤80%R.H)

General :

- **Display :**
3½ digit (2000 counts).
- **Low Battery Indication :**
"BAT" sign appears on the display when the battery voltage drops below accurate operating level.
- **Operating Principle :** Dual slope integration.
- **Conductor Size :** Approx. 55mm max
- **Overload protection :** AC 600V, DC 600V
- **Data Hold Indication :** HOLD
- **Response Time :** Approx. 1 second.
- **Sample Rate :** Approx. 2 times per second.
- **Dimensions :** 260(L) x 95(W) x 43(D)mm
- **Weight :** Approx. 540g (battery included)
- **Power source :**
One type PP3, 6F22, 006P(or equivalent), 9V manganese.
- **Temperature & Humidity for Guaranteed :**
23°C ±10°C at < 80% max. relative humidity.
- **Storage Temperature & Humidity :**
-20°C to 60°C at < 80% max. relative humidity.
- **Battery Life :**
Approx. 100 hours on continuous use. (Alkaline battery)
- **IEC/EN 61010-1 61010-2-32 CAT III 600V**

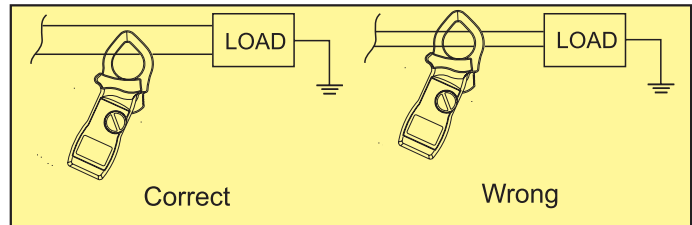
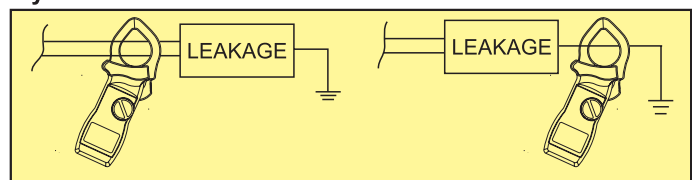
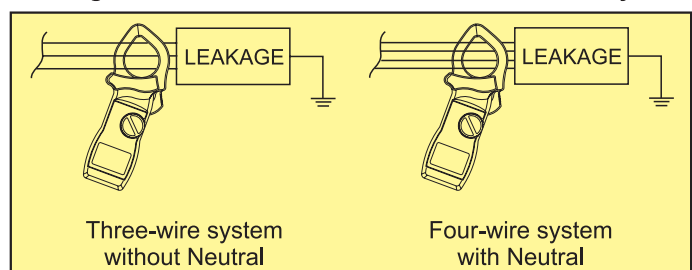
3920 CL
3921 CL
AC Current Measurement
Normal AC Current Measurements

Leakage Current Measurements on the Single-Phase System

Leakage Current Measurement on Three-Phase System



ST-3502

SPECIFICATIONS

DC Volts

Range	Analog Maximum	Resolution Digital	Accuracy		Protection
			Digital	Analog	
200mV	240mV	100uV	±(0.5%rdg+dgt)	±2%FSD	DC500V AC350V
V	2.4V	1mV			
2V	24V	10mV			
20V	240V	100mV			
200V	1000V	1V	±(1.5%rdg+5dgt)		DC1200V AC800V

Input impedance:10MΩ

AC Volts

Range	Analog Maximum	Resolution Digital	Accuracy		Protection
			Digital	Analog	
200mV	240mV	100uV	±(1%rdg+5dgt)	±3%FSD	DC500V AC350V
V	2.4V	1mV			
2V	24V	10mV			
20V	240V	100mV			
200V	1000V	1V	±(1.5%rdg+5dgt)		DC1200V AC800V

Input impedance:10MΩ

DC Current

Range	Analog Maximum	Resolution Digital	Accuracy		Protection
			Digital	Analog	
200uA	240uA	100nA	±(1%rdg+5dgt)	±3%FSD	800mA
2mA	2.4mA	1uA			
20mA	24mA	10uA			
200mA	240mA	100uA			
10A	10A	10mA	±(2%rdg+3dgt)		10A

AC Current

Range	Analog Maximum	Resolution Digital	Accuracy		Protection
			Digital	Analog	
200uA	240uA	100nA	±(1%rdg+5dgt)	±3%FSD	800mA
2mA	2.4mA	1uA			
20mA	24mA	10uA			
200mA	240mA	100uA			
10A	10A	10mA	±(2%rdg+3dgt)		10A

FEATURES

DIGITAL DISPLAY

- 3½ digit, high contrast LCD, with a maximum display of 1999.
- Automatic polarity indication, zero adjust.
- Low battery (BAT) indication.
- Overrange indication: highest digit of (1) or (-1).

ANALOG DISPLAY

- Large 90° wide and 84mm long mirror scale. (adapted to digital, analog maximum indication 2400).
- Shock and vibration resistant TAUT BAND movement.
- Switch selection normal (left hand side) zero or center (galvo-mode) zero. Polarity + or-, pointer turn to right hand side, avoid opposite direction.
- Center zero and ohm zero:automatic
- Dimensions:102(L) x 167(W) x 39(D)mm

Resistance

Range	Analog Maximum	Resolution Digital	Accuracy		Protection
			Digital	Analog	
200Ω	5KΩ	100mΩ	±(1%rdg+5dgt)	±4%arc -10Ω	50V DC
2KΩ	50KΩ	1mΩ			
20KΩ	500KΩ	10Ω			
200KΩ	5MΩ	100Ω			
2000KΩ	50MΩ	1KΩ	±(1.5%rdg+5dgt)	±4%arc	
20MΩ	500MΩ	10KΩ	±(1.5%rdg+5dgt)		

Capacitance

Range	Analog Maximum	Resolution Digital	Accuracy		Protection
			Digital	Analog	
2000pF	2400pF	1pF	±(3%rdg+10dgt)	±5%FSD	50mV 400Hz
20nF	24nF	10pF			
200nF	240nF	100pF			
2uF	2.4nF	1nF			
20uF	24uF	10nF			

Instant Continuity

Range	Analog Maximum	Resolution Digital	Continuity Indication	Protection
200Ω	5KΩ	100mΩ	Built Buzzer sounds when Resistance is less than 40Ω	3.2V MAX

Frequency

Range	Analog Maximum	Resolution Digital	Accuracy		Protection
			Digital	Analog	
2000Hz	2400Hz	1Hz	±(2%rdg+3dgt)	±3%FSD	350Vrms

Diode Test

Test Current 3.0 ±0.6mA

Test Voltage 3.2Max

HFE Test

Base DC Current 10A

Vce 2.8±0.4V

HFE 1000



STANDARD DIGITAL MULTIMETER



ST-3201

ST-3501

SPECIFICATIONS

DC Volts

Range	Resolution	Accuracy	Over voltage Protection
200mV	100nV	±(0.5%rdg+1dgt)	DC500V AC350V
2V	1mV		
20V	10mV		DC1200V AC800V
200V	100mV		
1000V	1V		

Input impedance: 10MΩ

DC Current

Range	Resolution	Accuracy	Over voltage Protection
200uA	100nA	±(1.0%rdg+1dgt)	325mV max
2mA	1uA		
20mA	10uA		
200mA	100uA	±(2.0%rdg+3dgt)	700mV max
10A	10mA		

Overload Protection 0.8A (250V) test blow fuse

AC Current(3501)

Range	Resolution	Accuracy 45Hz to 400Hz	Over voltage Protection
200uA	100nA	±(1.2%rdg+1dgt)	325mV max
2mA	1uA		
20mA	10uA		
200mA	100uA	±(2.0%rdg+3dgt)	700mV max
10A	10mA		

Overload Protection 0.8A (250V) test blow fuse

Resistance

Range	Resolution	Accuracy	Max Test Current	Max Open Circuit Voltage
200Ω	0.1Ω	±(1.0%rdg+3dgt)	3mA	3.2V
2KΩ	1Ω		250uA	
20KΩ	10Ω	±(0.8%rdg+1dgt)	50uA	0.3V
200KΩ	100Ω		5uA	
2MΩ	1KΩ	±(3.0%rdg+1dgt)	500nA	
20MΩ	10KΩ		50nA	

Overload Protection 500V DC/AC

FEATURES

- Display : 3 ½ digit liquid crystal display (LCD) with max. reading of 1999.
- Polarity : Automatic, (-) negative polarity indication.
- Zero Adjustment : Automatic.
- Over Range Indication : Highest digit of (1) or (-1) is displayed.
- Low Battery Indication : The (BAT) is displayed when the battery voltage drops below the operating voltage.
- Measurement Rate : 3 measurements per second, nominal.
- Operating Temperature : 0°C to 40°C 70% RH.
- Storage Temperature : -20°C to +60°C 80% RH, with battery removed.
- Accuracy : Accuracy specifications at 23 ± 5°C, less than 75% RH.
- Dimensions : 128(L) x 72(W) x 33(D)mm.
- Weight : Appro.200g(ST-3501), 183g(ST-3201)
- Power : 006P 9 volt batteryx1

AC Volts

Model	Range	Resolution	Accuracy	Over voltage Protection
3501	200mV	100uV	45Hz to 400Hz ±(1.2%rdg+4dgt)	DC500V AC350V
	2V	1mV		
	20V	10mV		DC1200V AC800V
200V	100mV			
3201	750V	1V	±(1.5%rdg+4dgt)	

Input impedance: 10MΩ(3501)

Resistance

Range	Resolution	Accuracy	Max Test Current	Max Open Circuit Voltage
	0.1Ω	Built Buzzer sounds when resistance is less then 80Ω	1.5mA	3.2V

Overload Protection 500V DC/AC

Capacitance (3501)

Range	Resolution	Accuracy	Over voltage Protection
2000PF	1pF	±(3%rdg+10dgt)	500mV 400Hz
20nF	10pF		
200nF	100pF		
2uF	1nF		
20uF	10nF		

HFE Test	Base DC Current	Vce	HFE	BATT Range	TEST(3201) Load
	10uA	2.8±0.4V	0 to 1000	1.5V	10Ω
Diode				9V	900Ω
Test Current	1.0 ±0.6mA			1.5V	4Ω
Test Voltage	3.2Max				

STANDARD ANALOG MULTIMETER



ST-365 TR

DC Volts : 0-0.01/0.5/2.5/10/50/250/1000V(20k Ω /V)
 AC Volts : 0-10/50/250/1000V
 DC mA : 50uA/2.5/25/250mA
 OHMS : 2K/20K/200K/2M/20M (20 Mid-Scale)
 Accuracy : $\pm 3\%$ F.S. DC. $\pm 4\%$ F.S. AC.
 Sensitivity : 20K/V DC. 8K/V AC.
 DB : -10 to ± 50 dB
 Hfe : 0-1000
 ICEO : 150uA, 1.5mA, 15mA, 150mA
 LV : 3V
 Dimension : 100 x 150 x 41mm
 Weight : 300g
 Power : Two "AA" 1.5V Battery.
 One 006P 9V Battery.

- IEC 1010-1 CAT.II 1000V



ST-360 TRn

DC Volts : 0-0.01/0.5/2.5/10/50/250/1000V(20K Ω /V)
 AC Volts : 0-10/50/250/1000V
 DC mA : 50uA/2.5/25/250mA
 OHMS : 2K/20K/2M/20M (20 Mid-Scale)
 Accuracy : $\pm 3\%$ F.S. DC. $\pm 4\%$ F.S. AC.
 Sensitivity : 20K/V DC. 8K/V AC.
 Db : -10 to ± 50 dB
 Hfe : 0-1000
 ICEO : 150uA, 15mA, 150mA
 Lv : 3V
 Dimension : 102 x 148 x 46mm
 Weight : 300g
 Power : Two "AA" 1.5V Battery.
 One 006P 9V Battery.

- IEC 1010-1 CAT.II 1000V



ST-505

- High quality Taut Band movement.

DCV : 0-0.25/1/2.5/10/50/250/1000V (50K Ω /V) $\pm 2\%$
 ACV : 0-2.5/10/50/250/1000V (10K Ω /V) $\pm 3\%$
 DCA : 0-25uA/1/25/500mA/10A(250mV drop) $\pm 2\%$
 ACA : 0-10A(250mV drop) $\pm 3\%$
 Resistance : 20K Ω , 200K Ω , 2M Ω , 20M Ω
 (Midscale 100 Ω)
 Decibel : -20 to 62dB
 Dimension : 145 x 101 x 47mm
 Weight : 550g
 Battery : 1.5V x 2



ST-520

DCV : 0-0.25/1/2.5/10/25/100/250/1000V
 (50K Ω /V) $\pm 3\%$
 ACV : 0-2.5/10/25/100/250/500/1000V
 (13K Ω /V) $\pm 4\%$
 DCA : 0.05/5/50/500mA. 0-12 $\pm 3\%$
 Resistance : 2K Ω , 20K Ω , 2M Ω , 20M Ω
 (Midscale 20, 200, 20k, 200k Ω)
 Decibel : -20 to 56dB(0dB=1Mw, 600 Ω)
 Dimension : 110 x 160 x 52mm
 Weight : 480g
 Battery : 1.5V x 2, 9V x 1
 For telecom and audio work.



STANDARD

RESISTOR CALIBRATION BOX

The RCB is also used to verify and proof any High Voltage Insulation Tester. It can be utilized to calibrate all High Voltage Insulation Testers very accurately : Analogs or Digitals.

Some institutions and large industries requested their own calibrator too, therefore, SEW started manufacturing the RCB for special customers.

Type	RCB-1	RCB-3
Resistance Range(Ω)	1M.2M.7M.10M.20M. .30M.50M.100M. 200M.500M.1G.2G. 5G.10G.20G.50G. 100G.200G.500G	1M.10M.100M.1G. 10G.100G.500G
Resistance Tolerances	$\pm 1\%$ (F)	
Temperature Coefficient	$\pm 25\text{ppm}/^\circ\text{C}$: 1M.2M.7M.10M.20M. 30M.50M.100M $\pm 50\text{ppm}/^\circ\text{C}$: 200M.500M $\pm 100\text{ppm}/^\circ\text{C}$: 1G.2G.5G $\pm 200\text{ppm}/^\circ\text{C}$: 10G.20G.50G.100G $\pm 400\text{ppm}/^\circ\text{C}$: 200G.500G	
Max. Working Voltage	DC 10KV	
Operating Temperature	$-30^\circ\text{C} \sim 75^\circ\text{C}$	
Power Consumption	Below 3W	
Connecting Terminals	Binding Post : Resistance circuit and guard	
Box Material	Aluminium	
Dimensions	450(L) x 330(W) x 180(D)mm	360(L) x 200(W) x 150(D)mm
Weight	Approx. 5kg	Approx. 2.25kg



RCB-1



RCB-3

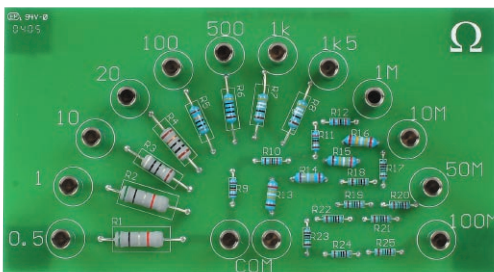

ITC 6



ITC 8

TYPICAL USES

- Checking ohm ranges of multimeters.
- Checking Low ohm range on insulation testers.
- Checking Insulation Mega Ohm ranges on insulation testers.
- Checking ohm ranges on Clamp Meters.
- Checking range on milli-ohm meters.
- Checking bench top multimeter's ohm range.
- ETC.....

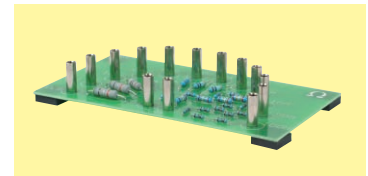

The ITC 8 can be utilized to check calibration of resistance ranges of insulation testers and multimeters. The resistance checker box is also used to verify insulation testers and multimeters.

- Resistance Ranges :
0.5 Ω , 1 Ω , 2 Ω , 20 Ω , 200 Ω , 1K Ω , 10K Ω ,
20K Ω , 100K Ω , 1M Ω , 2M Ω , 10M Ω
- Accuracy :
0.5 Ω - 2 Ω : $\pm 0.05\Omega$
20 Ω - 10M Ω : $\pm 1\%$
- Dimensions : 150(L) x 72(W) x 60(D) mm
- Weight : Approx. 180g
- IEC/EN 61010-1 CAT III 1000Vdc



STANDARD

MINI APPLIANCE CHECKER



When these three conditions are satisfied, the GREEN SAFE LED will lights up, showing that the appliance has checked SAFE according to the checker method of testing.

Always use the appliance simulator before and after using the checker on a real appliance, to ensure proper working condition of the checker.

Please note that due to the fact that this checker uses less than 10V for it's test, faulty voltage dependent devices could be undetected.

Application Example

The appliance is plugged into the mini appliance checker, then the probe make contact with the protective conductor.

CE

880 AT

The Mini Appliance Checker 880 AT is a simplified version of an appliance tester which use low voltage and low current to perform it's checks.

This is not intended to be used to perform certification testing.

It has been designed to be low cost and simple to use, But still has all the necessary basic functions to check a normal appliance.

It has been designed to be utilized by people who need to check the good status fo insulation and plug wiring, for example, before delivery of an appliance to a customer.

This Mini Appliance Checker also can be utilized to confirm the problematic status of an appliance which need servicing.

This checker verify that the resistance between the Line and Earth conductor connected to the appliance is more than 1M ohm.

If this is not the case, the L-E LED will light up, showing a likely insulation fault between L-E.

This checker verify that the resistance between the Neutral and Earth conductor connected to the appliance is more than 1M ohm.

If this is not the case, the N-E LED will light up, showing a likely insulation fault between N-E.

This checker verify that the resistance between the Earth Chassis of the appliance and the Earth conductor (at the plug) connected to the appliance is less than 10 ohms.

If this is not the case, the EARTH BOND LED will light up, showing a likely continuity fault between the earth at the plug and the chassis of the appliance.



Other appliance checking

Washing Machine Toaster Iron Dish Washer Stove



Comparison of conventional and patented terminal cover

The biggest vulnerability of the meter tester is the folded end, which often causes bad inner connection. Our patented screw end has completely offset the bending oppression, which makes it lasts at least ten times longer.

- Wire length : 1100mm
- Wire materials : UL1803 Temperature tolerance range +105 ° -45 °
PVC Outer Dimension: 4.0
- NC : 0.08/170*1C:TEL-AL11-1, TEL-AL11-3, TEL-AL11-4, TEL-AL11-A,
0.08/200*1C:TEL-AL11-1A, TEL-AL11-2A, TEL-AL11-3A,
TEL-AL11-4A, TEL-AL11-AA,
- Rating
170*1C:EN61010-031 CAT III 1000V 15A
200*1C:EN61010-031 CAT IV 1000V 15A

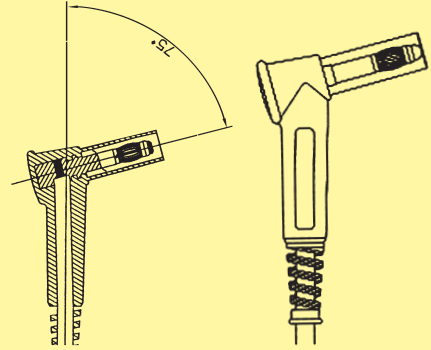
TEL-AL11-1

CE

TEL-AL11-2A

CE

TEL-AL11-3

CE

TEL-AL11-4

CE

TEL-AL11-A

CE



STANDARD TEST LEADS

- Probe End : TEL-AL28-1 and TEL-AL28-2 are $\varnothing 2\text{mm}$, other models are $\varnothing 4\text{mm}$.
The probe with brass nickel plated, with UI 125°C tube black. Molded UL 94V-0 PVC; color inside red and black outside grey.
- Connect End : $\varnothing 4\text{m/m}$ with brass nickel plated. Molded UL 94V-0 PVC; Color inside red and black outside grey.
- Wire : UL1803 18AWG 2000V 80°C One is red the other is black.
- Rating : EN61010-1 EN61010-2-31 1000V CAT.III 10A

TEL-AL28-1

CE

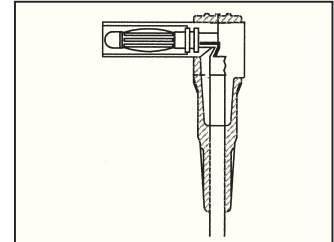

TEL-AL28-2

CE

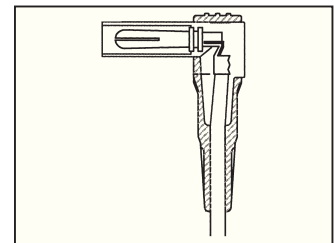

TEL-AL28-3

CE

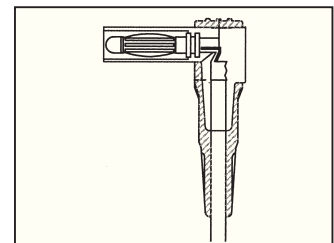
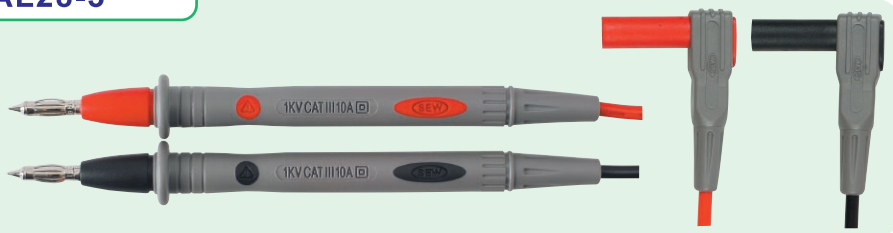

TEL-AL28-4

CE

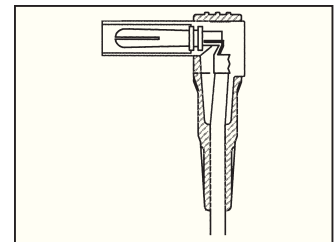

TEL-AL28-5

CE

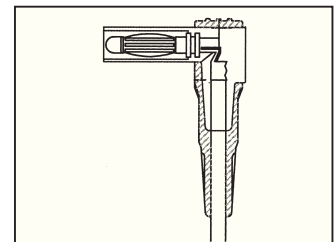
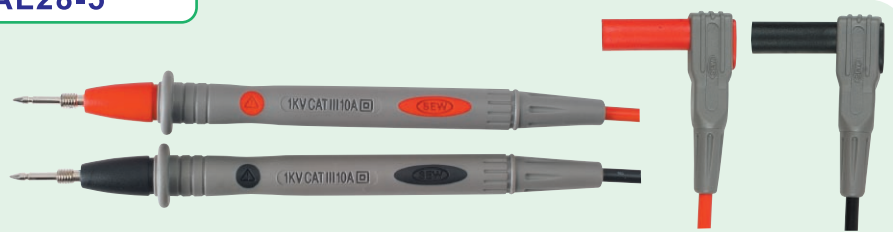

TEL-AL28-6

CE

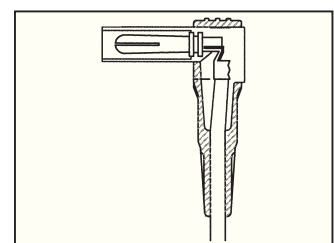

Kit No. TEL-AL29



Probe End : The brass 2mm probe tip (length : 18mm)
 Connect End : 4mm banana plug
 Wire : UL1803 18AWG (length : 1200mm)
 Rating : EN61010-1 EN61010-2-31 1000V CAT.III 10A

Kit No. AL-24A



(AL-24 without crocodiles clips)

The brass 2mm probe tip (length : 17mm).
 PVC-insulated 3.5mm, 64pieces/0.12mm wires.
 (length : 840mm)
 Right-angle 4mm brass banana plug with caged and insulated sheathing to avoid the brass oxidation.
 The probe tip could screw into crocodile clips.

Kit No. AL-24SA



(AL-24S without crocodiles clips)

The brass 2mm probe tip (length : 22mm).
 PVC-insulated 3.5mm, 64/0.12mm wires (length : 900mm).
 Safety straight 4mm brass caged input plug with spring-sheathing and insulated tip.
 The probe tip could screw into crocodile clips.

Kit No. AL-25A



(AL-25 without crocodiles clips)

The brass 4mm probe tip (length : 17mm)
 PVC-insulated 3.5mm, 64pieces/0.12mm wires.
 (length : 900mm)
 Right-angle 4mm brass banana plug with caged and insulated sheathing to avoid the brass oxidation.
 The probe tip could screw into crocodile clips.

Kit No. AL-26



The brass 2mm probe tip (length : 14mm)
 PVC-insulated 3.5mm, 64pieces/0.12mm wires.
 (length : 900mm)
 Right-angle 4mm brass banana plug with caged and insulated sheathing to avoid the brass oxidation.
 Rating: BSEN61010-1 IEC1010-1 BSEN61010-2-31 CAT III 1000V 10A.

Kit No. AL-30, AL-30F

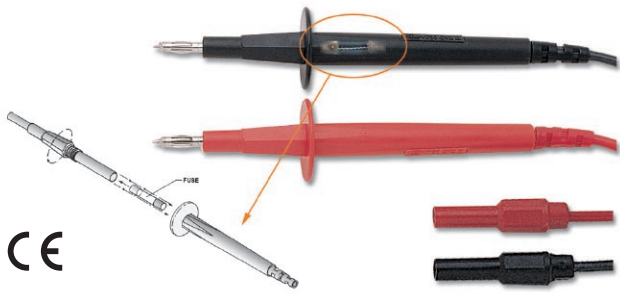

The spring-shrouded 4mm brass caged banana probe tip, double Insulated silicone wire 1m, safety straight input plug.
 Rating: EN61010-1 EN61010-2-31 CAT III 1000V 10A
AL-30R Red, AL-30B Black, AL-30G Green
< AL-30F >
 It is the fused version for AL-30.
AL-30FR Red, AL-30FB Black

Kit No. AL-30A

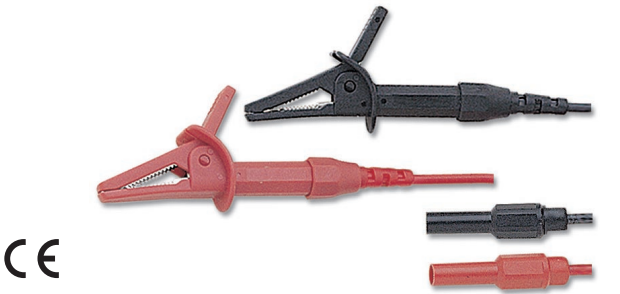

Wide grip crocodile clips with integral finger guard, large 35mm high tension spring mouth. Double insulated silicone wire 1m. Safety straight input plug.
 Rating: EN61010-1 EN61010-2-31 CAT III 1000V 10A
AL-30AR Red
AL-30AB Black
AL-30AG Green

Kit No. AL-30C

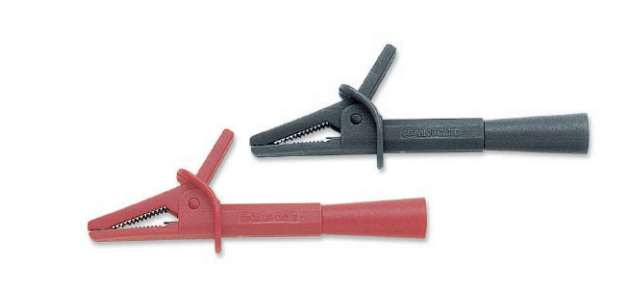

Wide grip crocodile clips with integral finger guard, large 35mm high tension spring mouth. Hexagonal Anti-rotation part fits all compatible 4mm male leads.
AL-30AR Red
AL-30AB Black

Kit No. AL-32, AL-32F

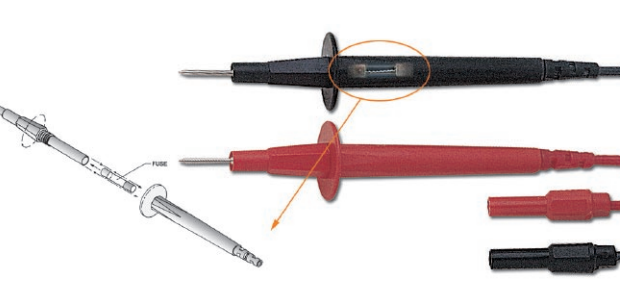

2mm probe tip double insulated silicone wire 1m, safety straight input plug.
AL-32R Red, AL-32B Black
< AL-32F >
 It is the fused version for AL-32.
AL-32FR Red, AL-32FB Black

Kit No. AL-33

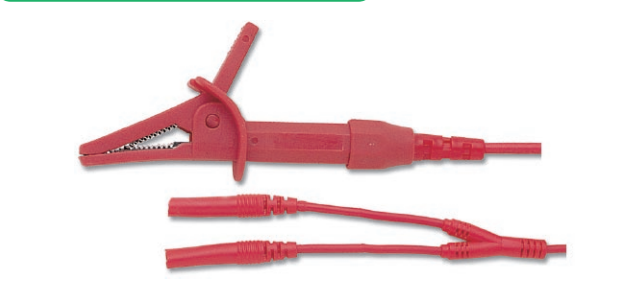

Color : Red
 Wide grip crocodile clips with integral finger guard, large 35mm high tension spring mouth. PVC-insulated wire 1.2m with branched straight input plugs.

STANDARD TEST LEADS

Kit No. AL-34



Wide grip crocodile clips with integral finger guard, large 35mm high tension spring mouth. PVC-insulated wire 50cm. Right-angle connectors.

**AL-34ARL Red, AL-34ABL Black,
AL-34ANL Blue, AL-34AWL White,
AL-34AYL Yellow**

Kit No. AL-35, AL-35F

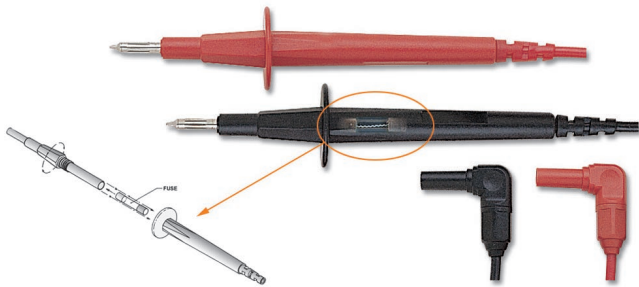

The spring-shrouded 4mm brass caged banana probe tip, double insulated silicone wire 1m, shrouded right-angle connector.

AL-35R Red, AL-35B Black

< **AL-35F** >

It is the fused version for AL-35.

AL-35FR Red, AL-35FB Black

Kit No. AL-36



(without auxiliary earth bars)

Wide grip crocodile clips with integral finger guard, large 35mm high tension spring mouth. PVC-insulated wire (Red-15m, Yellow-10m, Green-5m). Right-angle connector.

AL-36R Red

AL-36Y Yellow

AL-36G Green

Kit No. AL-37

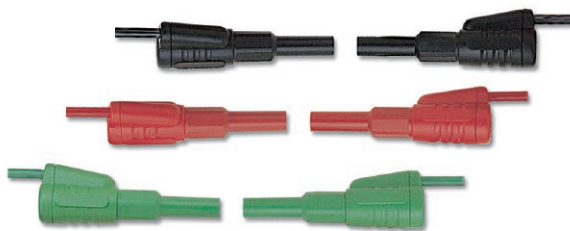

Stacking shrouded plug each end. Silicone wire 50cm.

AL-37R Red

AL-37B Black

AL-37G Green

Kit No. AL-37H

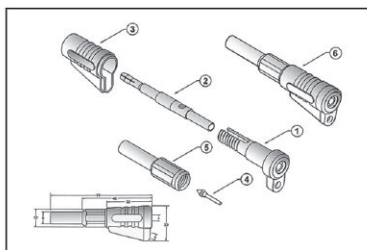

Stacking shrouded plug.

AL-37HR Red

AL-37HB Black

AL-37HG Green

Kit No. AL-38C



Wide grip crocodile clips with integral finger guard, large 35mm high tension spring mouth. Fits all compatible 4mm standard banana terminal.

- AL-38CR Red**
- AL-38CB Black**

Kit No. AL-39

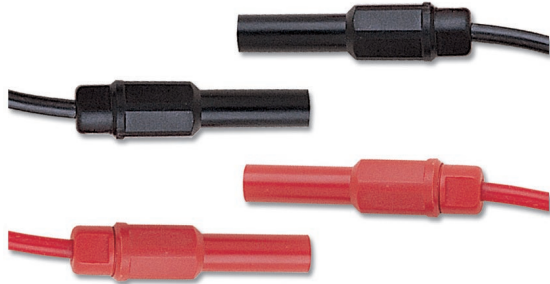

Stacking shrouded banana plug, each end on 1.2m long silicone wire.

- AL-39R Red**
- AL-39B Black**

Kit No. AL-39H

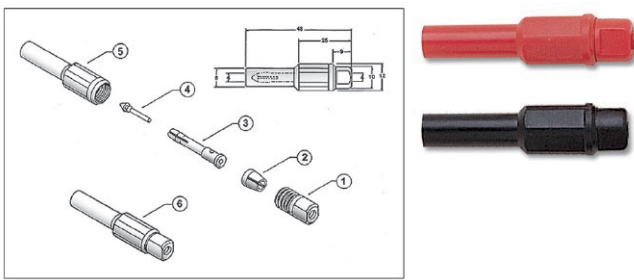

Stacking shrouded plug.

- AL-39HR Red**
- AL-39HB Black**

Kit No. AL-50

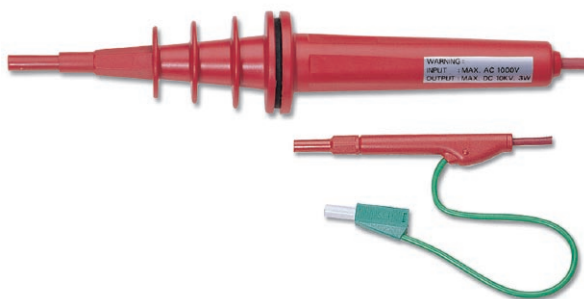

Color : Red

Large test probe handle with shrouded 4mm brass caged banana Plug tip, super insulated silicone wire 2.7m, safety straight input plug connect with extra green guard.

WARNING :

INPUT : MAX. AC 1000V

OUTPUT : MAX. DC 10KV. 3W

ONLY AVAILABLE FOR INSULATION TESTER.

Kit No. AL-55



DISCHARGE ROD

Color : Black

Large test probe handle with shrouded 4mm brass caged banana Plug tip.

Super insulated silicone wire 1.5m, safety straight input plug.

Alligator Clip



TEL-AL23C

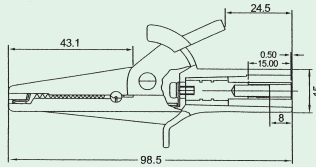

- For 4mm banana plug
- IEC/EN 61010-031
- CAT III 1000V/CAT IV 600V 10A

TEL-AL24C

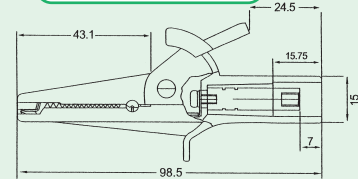

- For 4mm screw

Alligator Clip



TEL-AL25C

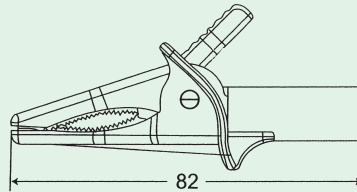

- For 4mm banana plug

Insulated Spade Lug

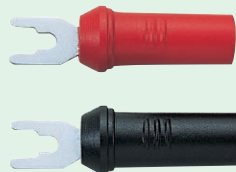
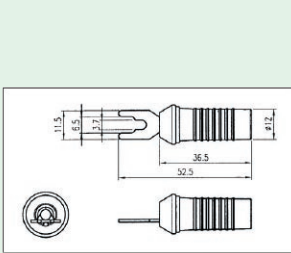

Solid copper spade lug. Designed to fasten housing or screws for measurement.

Fully insulated, axial mount 4mm banana jack.

Designed especially for terminal posts,

The Y-shaped tip accepts housings or screws that have a diameter of 6.5mm or less.

Connectors Terminal

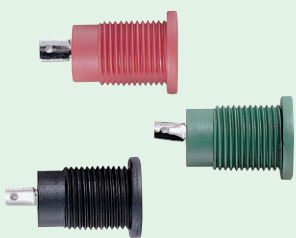

Sockets nylon

4 m/m sockets with shrouded contact compatible with shrouded plugs and leads supplied with nuts for panel mounting.

- TER-6200B Black,
- TER-6200R Red,
- TER-6200G Green

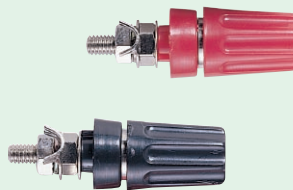

4 m/m sockets with insulated head and base for installation in unit.

ABS resin head.

- TER-205B Black
- TER-205R Red

Connectors Terminal



4 m/m banana socket captive head suitable for wire or pin-type test head bakelite material head and base.

- TER-305B Black

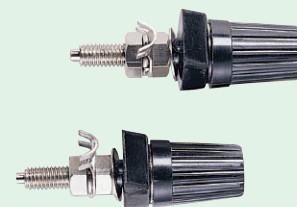

5 m/m captive head suitable for wire or pin-type test head bakelite material base.

- TER-2000

PACKING INFORMATION

MODEL	QTY/CTN	N.W	G.W	GUFT	PAGE	MODEL	QTY/CTN	N.W	G.W	GUFT	PAGE
ST-2550	8	10.0	11.0	3.20	3	6211AIN	4	17.0	18.0	4.60	48
ST-2551	8	10.0	11.0	3.20	3	6212AIN	4	17.0	18.0	4.60	49
ST-1503	8	9.0	10.0	3.20	4	6220 EL	4	17.0	18.0	4.60	49
ST-1504	8	9.5	10.5	3.20	4	6237 DLRO	4	17.0	18.0	4.60	52
ST-1520	8	16.5	17.5	3.20	5	270 HP	12	10.0	11.0	2.61	53
ST-1505	8	16.5	17.5	3.20	6	275 HP	12	10.0	11.0	2.61	54
1506 IM	10	9.0	10.0	2.07	6	276 HD	20	7.5	8.5	2.07	55
1851 IN	12	16.0	16.5	3.40	7	276S HD	20	7.5	8.5	2.07	55
1800 IN	12	16.0	16.5	3.40	8	285 HD	30	5.5	6.5	1.68	56
1801 IN	12	16.0	16.5	3.40	8	288 SVD	20	4.5	5.5	1.68	57
1832 IN	12	16.0	16.5	3.40	9	PD-20	10	5.5	6.5	3.00	58
1820 ER	8	18.0	19.5	4.60	10	PD-28	15	9.0	10.0	4.60	58
1805 ER	8	18.5	20.0	4.60	11	PC 7K	1	6.5	11.0	3.50	59
1811 EL	12	17.0	15.5	3.40	12	PC 11K	1	7.0	11.5	3.50	59
1812 EL	12	17.0	15.5	3.40	12	PC 22K	1	7.5	13.0	4.27	59
1813 EL	12	17.0	15.5	3.40	13	PC 33K	1	8.0	13.5	4.27	59
1810 EL	12	17.0	15.5	3.40	14	PC 44K	1	8.5	12.5	4.50	59
1824 LP	12	19.0	15.5	3.40	15	2310 SL	10	8.5	9.5	2.50	64
1825 LP	12	19.0	15.5	3.40	16	2330 LX	20	10.0	11.0	1.68	64
1826 NA	12	19.0	15.5	3.40	17	180 CB	20	9.5	10.5	2.86	65
2120 ER	8	23.0	24.0	4.60	18	190 CBI	20	8.0	9.0	3.18	65
2751 IN	8	11.0	12.0	3.20	19	191 CBI	20	8.0	9.0	3.18	65
2732 IN	8	11.0	12.0	3.20	20	ST-850	20	13.5	14.5	2.25	67
2720 ER	6	15.0	16.0	3.10	21	855 PR	20	14.0	15.0	2.25	67
2705 ER	6	15.0	16.0	3.10	23	862 PR	20	8.5	9.5	2.25	68
2706 IM	8	11.0	12.0	3.20	23	863 PR	20	8.5	9.5	2.25	68
2712 EL	8	11.5	12.5	3.20	24	ST-860	20	10.0	11.0	2.25	71
2726 NA	8	11.0	12.0	3.20	26	ALS-1	100	13.5	14.5	2.07	71
2801 IN	10	13.5	14.5	3.20	27	ST-375	20	17.0	18.0	2.09	72
2803 IN	10	18.5	19.5	3.20	28	ST-600	20	17.0	18.0	2.09	72
2804 IN	10	18.5	19.5	3.20	28	ST-1000	20	17.0	18.0	2.09	72
2811 LP	10	13.0	14.0	3.20	29	ST-2600	20	13.0	14.0	2.50	73
2820 EL	10	13.0	14.0	3.20	30	3800 CL	20	17.0	18.0	2.09	73
4101 IN	8	17.5	18.5	4.60	31	3810 CL	20	17.0	18.0	2.09	73
4132 IN	8	17.5	18.5	4.60	33	ST-3600	20	17.0	18.0	2.09	74
4103 IN	8	18.5	20.0	4.60	34	ST-3602	20	17.0	18.0	2.09	74
4104 IN	8	18.5	20.0	4.60	34	ST-3620	20	17.0	18.0	2.09	74
4120 ER	8	18.5	20.0	4.60	35	3900 CL	20	17.5	18.5	3.10	75
4105 ER	8	18.5	20.0	4.60	35	3902 CL	20	17.5	18.5	3.10	75
4112 EL	8	17.5	18.5	4.60	37	3904 CL	20	17.5	18.5	3.10	75
4126 NA	8	17.5	18.5	4.60	38	3920 CL	20	17.5	18.5	3.10	76
4136 mO	8	17.5	18.5	4.60	39	ST-3502	20	16.5	17.5	2.25	77
4137 mO	8	17.5	18.5	4.60	39	ST-3201	40	12.0	13.0	2.07	78
4156 PR	8	17.5	18.5	4.60	40	ST-3501	30	9.5	10.5	1.31	78
4183 CP	8	17.5	18.5	4.60	41	ST-365TR	20	10.0	11.0	2.05	79
6200 IN	4	17.0	18.0	4.60	47	ST-360TR _N	20	10.0	11.0	2.05	79
6201 IN	4	17.0	18.0	4.60	47	ST-505	20	12.0	13.0	2.25	79
6210AIN	4	17.0	18.0	4.60	48	ST-520	20	10.0	11.0	2.25	79

